

Workman™ Wet/Dry Vacuums

Operator's Manual Parts Schematic



Workman™
10 - Gallon **Item #85026-00**

Workman™
10 - Gallon w/Dolly **Item #85017-00**

Workman™
6 - Gallon **Item #85025-00**

Workman™
3 - Gallon **Item #85024-00**

Chemicals

Equipment

Programs

Process

BETCO®

Workman™ 3, 6, & 10-Gallon Wet/Dry Vacuums

Table of Contents

Technical Information & Safety	Page	3, 4
Preparation & Operation	Page	5
After Use & Maintenance	Page	5
Part Schematic:		
Workman 3-Gallon	Page	6, 7
Workman 6-Gallon	Page	8, 9
Workman 10-Gallon	Page	10, 11
Workman 10-Gallon TP (Metal cart)	Page	12, 13

Workman™ 3, 6, & 10-Gallon Wet/Dry Vacuums

Technical Information

Tank Size	85024-00 3-Gallon 85025-00 6-Gallon 85026-00 10-Gallon 85027-00 10-Gallon
Vacuum Motor (All Models)	1.75 hp (2-stage bypass)
Noise Level (All Models)	65 dB
Filtration (All Models)	Cloth
Airflow (All Models)	125 cfm
Water Lift (All Models)	98"
Power Cord (All Models)	50'
Transport Dolly	85027-00 Workman 10DLY Only
Diameter	85024-00 15" 85025-00 15.5" 85026-00 16" 85027-00 20"
Height	85024-00 21.5" 85025-00 26" 85026-00 30" 85027-00 32"
Weight	85024-00 16 lbs 85025-00 18 lbs 85026-00 31 lbs 85027-00 35 lbs
Tool Kit (All Models)	Included
Productivity (All Models)	W/14" Tool: 2,500 sq. ft./hour

General Safety Information

When using an electrical appliance, basic precautions should always be followed, read all instructions before using.

! WARNING! To reduce risk of fire, electric shock, or injury:

- Do not leave the machine when it is plugged in. Unplug the unit from the outlet when not in use & before servicing.
- To avoid electric shock, do not expose machine to rain. Store indoors.
- Do not allow to be used as a toy. Close attention is necessary when used by or near children.
- Use only as described in this manual. Use only manufacturer's recommended attachments.
- Do not use with damaged cord or plug. If machine is not working as it should return it to a service center for inspection.
- Do not pull or carry by cord, use cord as a handle, close a door on a cord, or pull cord around sharp edges or corners. Do not run machine over cord. Keep cord away from heated surfaces.
- Do not unplug by pulling on cord. To unplug, grasp the plug, not the cord.
- Do not handle plug or machine with wet hands.
- Do not put any foreign object into openings. Do not use with any opening blocked; keep free of dust, lint, hair, & anything that may reduce airflow.
- Keep hair, loose clothing, fingers, & all parts of body away from openings & moving parts.
- Turn off all controls before unplugging.
- Do not use in or around flammable or combustible liquids such as gasoline or use in areas where they may be present.
- Connect to a properly grounded outlet only. See grounding instructions.

Grounding Instructions

This machine must be grounded. If it should electrically malfunction, grounding provides a path of least resistance for electric current to reduce the risk of electric shock. This machine is equipped with a cord having an equipment-grounding conductor & grounding plug. The plug must be plugged into an appropriate outlet that is properly installed & grounded in accordance with all local codes & ordinances.

! DANGER !

Improper connection of the equipment-grounding conductor can result in a risk of electric shock. Check with a qualified electrician or service person if you are in doubt as to whether the outlet is properly grounded. Do not modify the plug provided with the machine. If plug will not fit the outlet, have a proper outlet installed by a qualified electrician.

Replace the plug if the grounding pin is damaged or broken.

Extension cords connected to this machine should be 12 gauge, 3-wire cords with 3-prong plugs & outlets. DO NOT use extension cords more than 50 feet long.

Preparation and Operation

Unwrap the power cord completely & plug into a properly grounded outlet.

For wet pick up remove dry filter assembly.

For dry pickup install cloth filter bag.

Attach swivel hose connector and hose to tank inlet.

Select proper floor tool. Wet squeegee for wet pick up. Dry floor tool for dry pick up. Install selected tool on 2-bend wand.

Turn switch located on vacuum head to on position.

You are now ready to begin your cleaning task.

After Use

Unplug the power cord, starting from the machine wrap the power cord onto the head assembly.

Completely empty tank of water and debris. Flush tank and dry with a clean towel.

Wipe vacuum head assembly with damp towel.

Wipe the entire machine with a clean, damp cloth.

Inspect the machine & all accessories for damage. Perform any required maintenance or repairs before storage.

Store the machine in a clean, dry place.

Workman Wet/Dry Vacuum 3-Gallon

View#	Betco SKU	Cross Ref.	Vacuum Head Parts
NA	8324500	1300/115V HEAD	Complete Vacuum Head
9	8203600	60048GR	Handle Motor Top
10	8203700	60002	Screw
11	8203800	10531	Switch
12	8203900	60046/15-50'	50' Power Cord
13	8204000	60007GR/1	Motor Cover Switch Housing
14	8204100	60010	Screw
15	8204200	40506	Strain Reliever
16	8204300	60049GRS	Upper Motor Housing Sleeve
17	8204400	60022	Upper Motor Plate
18	8204500	95006	Upper Spacer Ring
19	8204600	ALT1	Spacer
20 & 22	8204700	60037	Motor Gasket (View20&22 Same Item)
21	8204800	58016/115	Motor 115V
23	8204900	60027GR	Bottom Mounting Plate
24	8205000	60028	Gasket For Mount Plate
25	8205100	27014	Float
26	8205200	58023	Float Cage
View#	Betco SKU	Cross Ref.	Tanks and Casters Parts
30		95005/Plas/C	3 Gal Tank
31	8202700	PL061	Plastic Tank Clamps
32	8203200	60043GR	Tank Intake Hose Connector
35		32002	3 Gal Tank Caster
View#	Betco SKU	Cross Ref.	Filters and Tools
1	8332200	40136	2 Bend Steel Wand
2	8324600	95018	Foam Filter For Float
3	8201900	40142	Plastic Wand
4	8202000	36031	Dusting Tool
5	8202100	40134	Crevice Tool
6	8202200	40138	Hard Floor Brush Tool
7	8328400	40130	Vacuum Hose
8	8202300	40139	Squeegee Tool
27	8309900	PL109	3 Gal Complete Cloth Filter

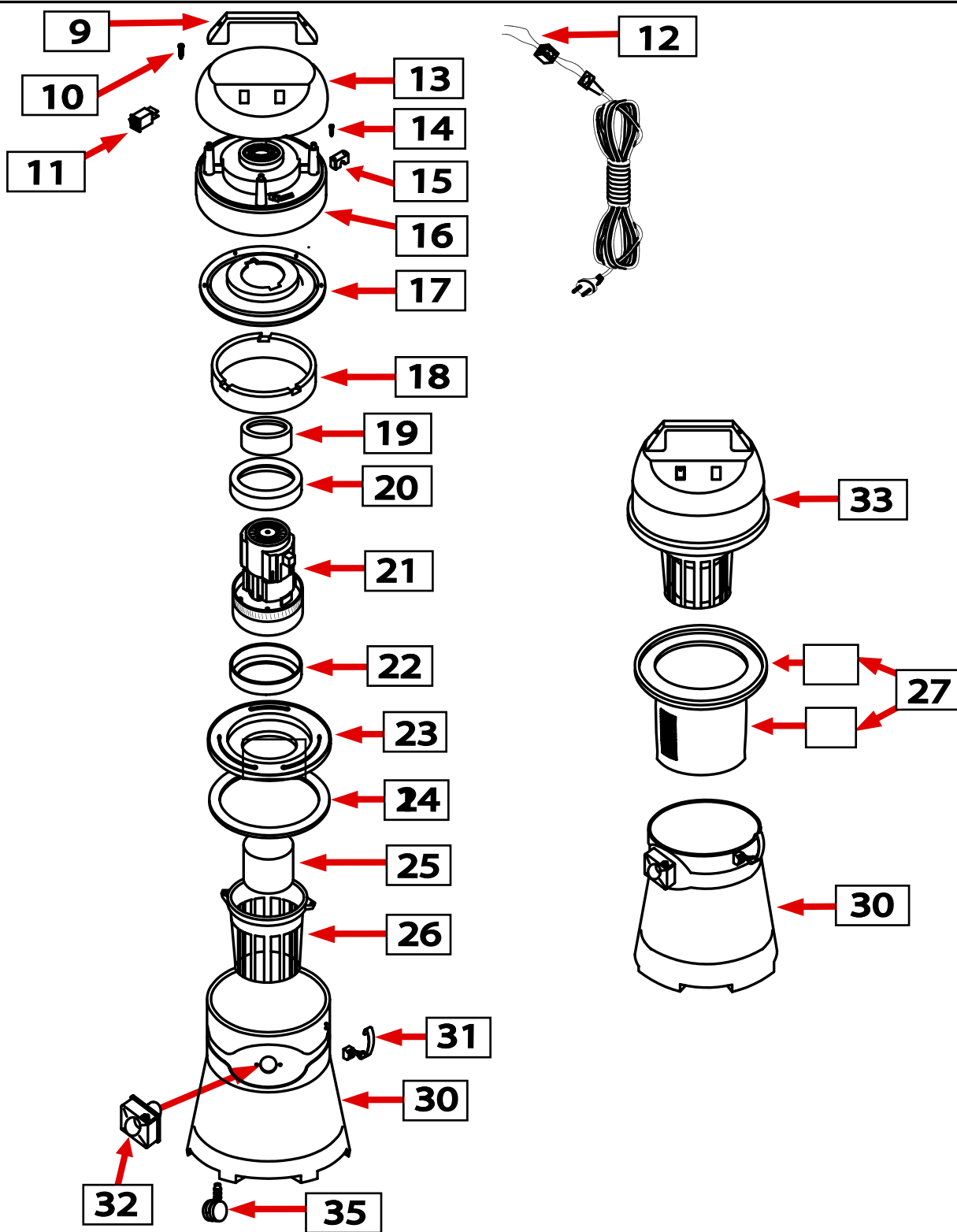
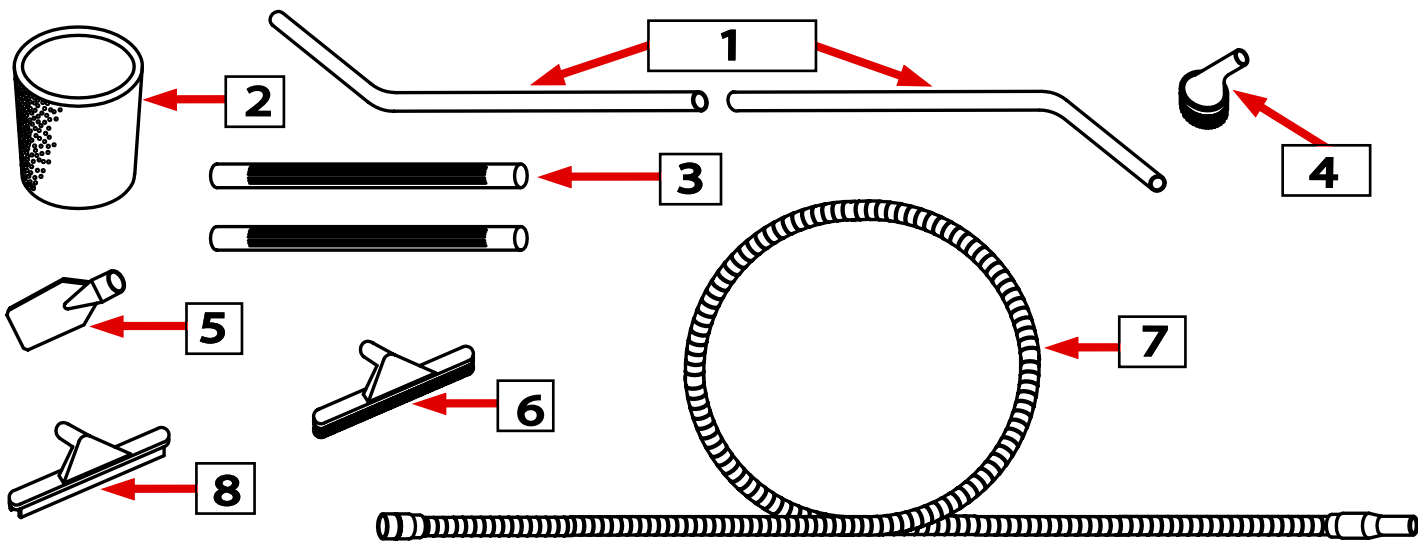

Workman Wet/Dry Vacuum 6-Gallon

View#	Betco SKU	Cross Ref.	Vacuum Head Parts
NA	8324500	1300/115V HEAD	Complete Vacuum Head
9	8203600	60048GR	Handle Motor Top
10	8203700	60002	Screw
11	8203800	10531	Switch
12	8203900	60046/15-50'	50' Power Cord
13	8204000	60007GR/1	Motor Cover Switch Housing
14	8204100	60010	Screw
15	8204200	40506	Strain Reliever
16	8204300	60049GRS	Upper Motor Housing Sleeve
17	8204400	60022	Upper Motor Plate
18	8204500	95006	Upper Spacer Ring
19	8204600	ALT1	Spacer
20 & 22	8204700	60037	Motor Gasket (View20&22 Same Item)
21	8204800	58016/115	Motor 115V
23	8204900	60027GR	Bottom Mounting Plate
24	8205000	60028	Gasket For Mount Plate
25	8205100	27014	Float
26	8205200	58023	Float Cage
View#	Betco SKU	Cross Ref.	Tanks and Casters Parts
30		27002/Plas/C	6 Gal Tank
31	8202700	PL061	Plastic Tank Clamps
32	8203200	60043GR	Tank Intake Hose Connector
35		32002	6 Gal Tank Caster
View#	Betco SKU	Cross Ref.	Filters and Tools
1	8332200	40136	2 Bend Steel Wand
2	8324600	95018	Foam Filter For Float
3	8201900	40142	Plastic Wand
4	8202000	36031	Dusting Tool
5	8202100	40134	Crevice Tool
6	8202200	40138	Hard Floor Brush Tool
7	8328400	40130	Vacuum Hose
8	8202300	40139	Squeegee Tool
27	8309900	PL109	6 Gal Complete Cloth Filter

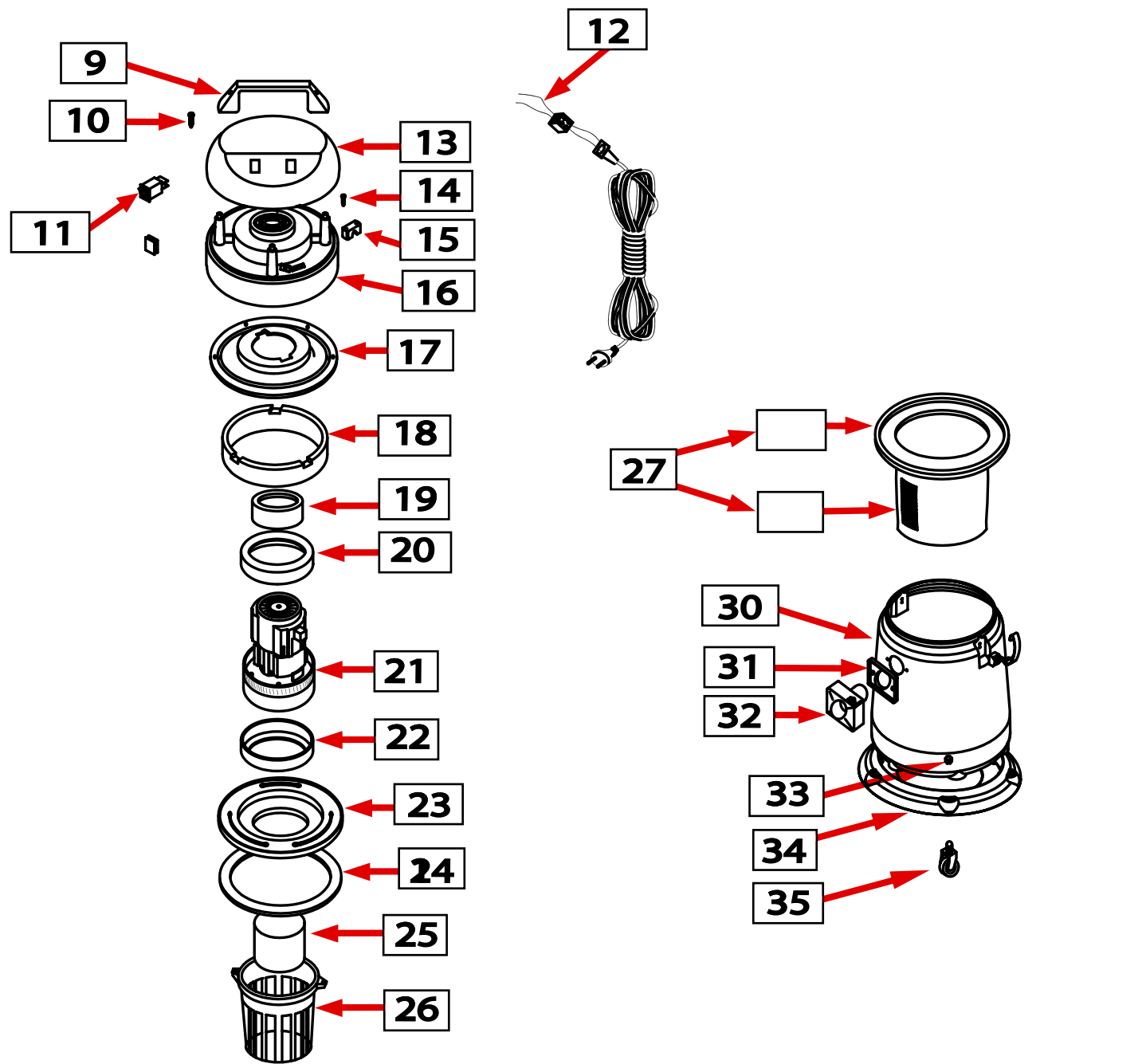
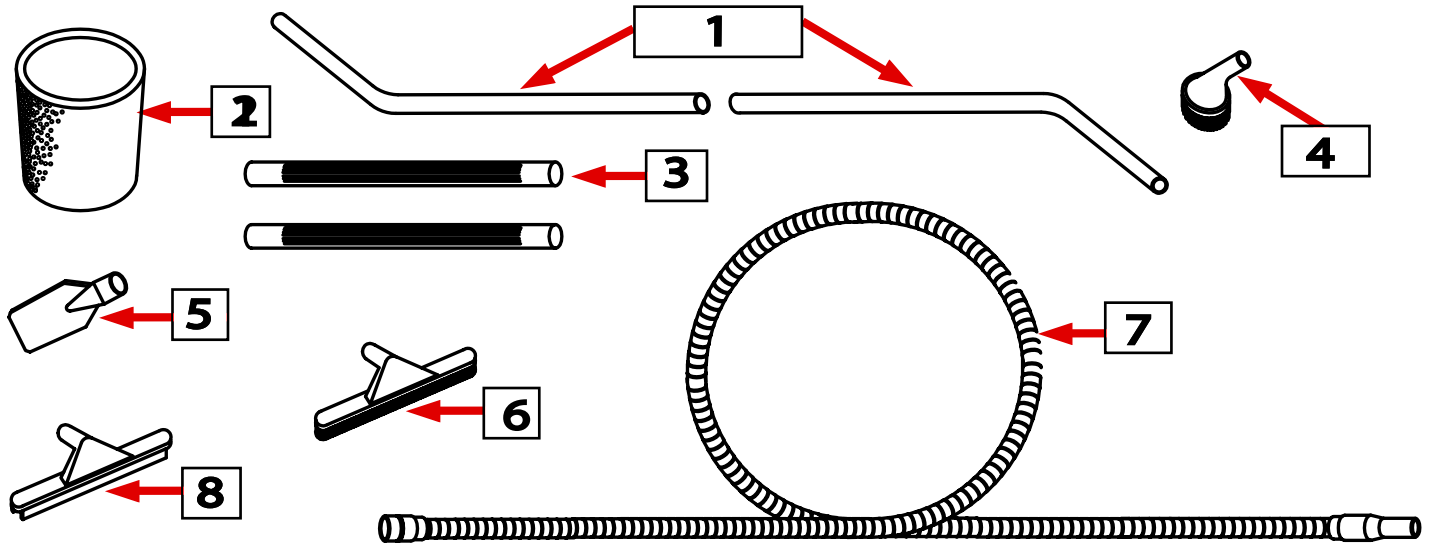

Workman Wet/Dry Vacuum 10-Gallon

View#	Betco SKU	Cross Ref.	Vacuum Head Parts
NA	8324500	1300/115V HEAD	Complete Vacuum Head
9	8203600	60048GR	Handle Motor Top
10	8203700	60002	Screw
11	8203800	10531	Switch
12	8203900	60046/15-50'	50' Power Cord
13	8204000	60007GR/1	Motor Cover Switch Housing
14	8204100	60010	Screw
15	8204200	40506	Strain Reliever
16	8204300	60049GRS	Upper Motor Housing Sleeve
17	8204400	60022	Upper Motor Plate
18	8204500	95006	Upper Spacer Ring
19	8204600	ALT1	Spacer
20 & 22	8204700	60037	Motor Gasket (View20&22 Same Item)
21	8204800	58016/115	Motor 115V
23	8204900	60027GR	Bottom Mounting Plate
24	8205000	60028	Gasket For Mount Plate
25	8205100	27014	Float
26	8205200	58023	Float Cage
View#	Betco SKU	Cross Ref.	Tanks and Casters Parts
30	8208800	60070	10 Gal Tank
31	8208900	60017	Tank Intake Gasket
32	8203200	60043GR	Tank Intake Hose Connector
33	8329000	77.014	Caster Nut
34	NA		Plastic Tank Base
35	8209000	10552	10 Gal Caster
NA	8202700	PL061	Plastic Tank Clamps
View#	Betco SKU	Cross Ref.	Filters and Tools
1	8332200	40136	2 Bend Steel Wand
2	8324600	95018	Foam Filter For Float
3	8201900	40142	Plastic Wand
4	8202000	36031	Dusting Tool
5	8202100	40134	Crevice Tool
6	8202200	40138	Hard Floor Brush Tool
7	8328400	40130	Vacuum Hose
8	8202300	40139	Squeegee Tool
27	8309900	PL109	10 Gal Complete Cloth Filter

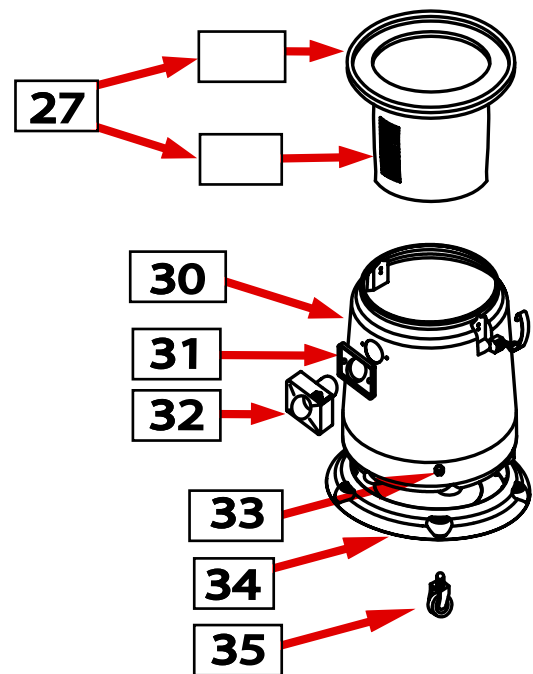
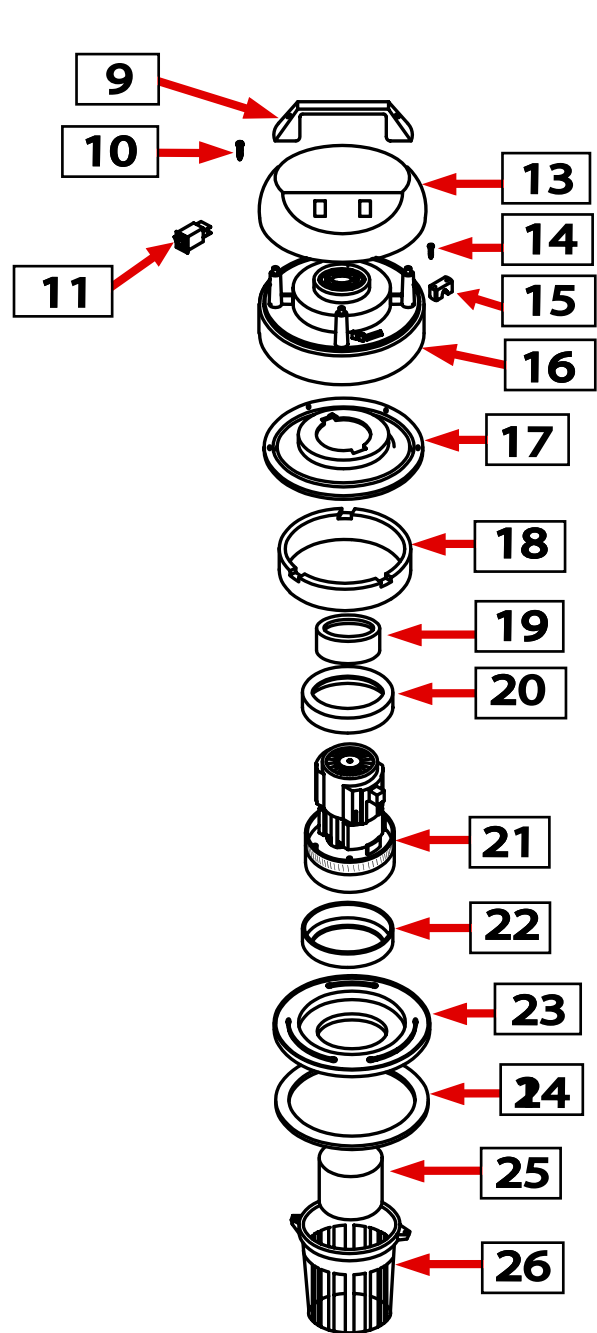
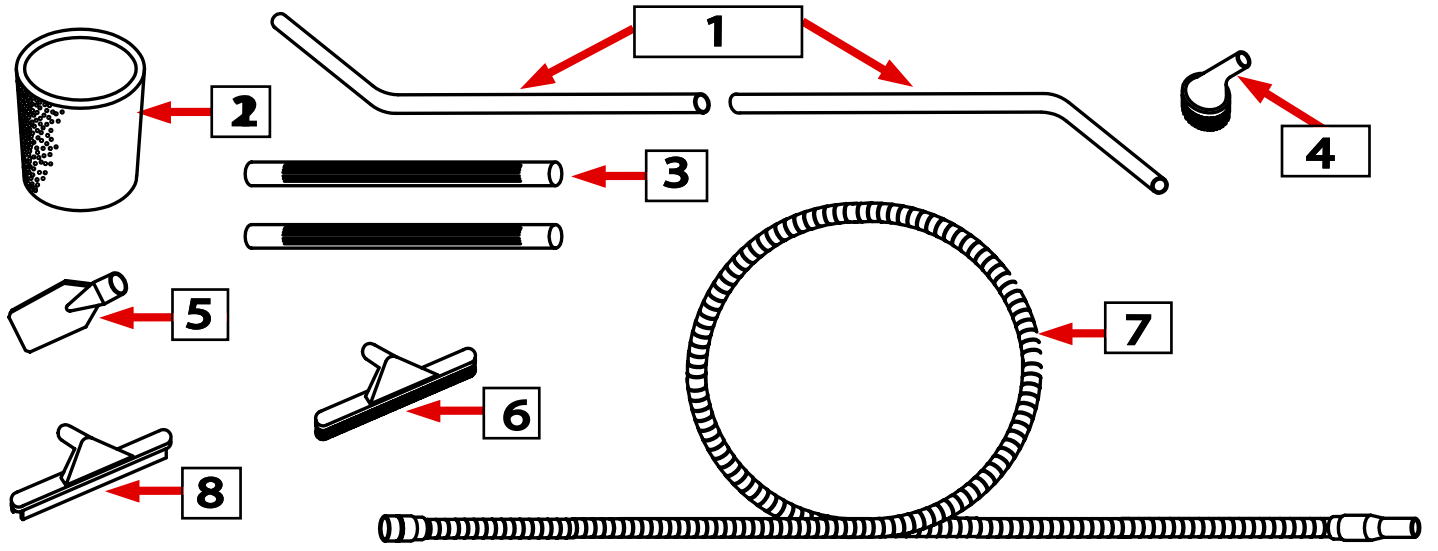

Workman Wet/Dry Vacuum 10-Gallon Tip Pour Metal Cart

View#	Betco SKU	Cross Ref.	Vacuum Head Parts
NA	8324500	1300/115V HEAD	Complete Vacuum Head
9	8203600	60048GR	Handle Motor Top
10	8203700	60002	Screw
11	8203800	10531	Switch
12	8203900	60046/15-50'	50' Power Cord
13	8204000	60007GR/1	Motor Cover Switch Housing
14	8204100	60010	Screw
15	8204200	40506	Strain Reliever
16	8204300	60049GRS	Upper Motor Housing Sleeve
17	8204400	60022	Upper Motor Plate
18	8204500	95006	Upper Spacer Ring
19	8204600	ALT1	Spacer
20 & 22	8204700	60037	Motor Gasket (View20&22 Same Item)
21	8204800	58016/115	Motor 115V
23	8204900	60027GR	Bottom Mounting Plate
24	8205000	60028	Gasket For Mount Plate
25	8205100	27014	Float
26	8205200	58023	Float Cage
View#	Betco SKU	Cross Ref.	Tanks and Casters Parts
30	8208800	60070	10 Gal Tip Pour Tank
31	8208900	60017	Tank Intake Gasket
32	8203200	60043GR	Tank Intake Hose Connector
33	832900	77.014	Caster Nut
34	NA	60.151	Rubber Bumper
35	820900	10552	10 Gal Tip Pour Front Caster
37	NA	58.035	10 Gal Tip Pour Rear Wheel
38	NA	58.074	10 Gal Tip Pour Cart Assembly
40	NA	58.07	Tank Mounting Bracket
41	NA	10.517	Tank Mounting Bolt
42	NA	58.005	Washer
43	NA	90.039	Washer
NA	8202700	PL061	Plastic Tank Clamps
NA	NA	NA	10 Gal Tip Pour Tank Handle
View#	Betco SKU	Cross Ref.	Filters and Tools
1	8332200	40136	2 Bend Steel Wand
2	8324600	95018	Foam Filter For Float
3	8201900	40142	Plastic Wand
4	8202000	36031	Dusting Tool
5	8202100	40134	Crevice Tool
6	8202200	40138	Hard Floor Brush Tool
7	8328400	40130	Vacuum Hose
8	8202300	40139	Squeegee Tool
28	8309900	PL109	10 Gal Complete Cloth Filter
NA	8201600	NA	Front Mount Squeegee Assembly

