

FL17

ORDER #85009

17" Floor Machine

FEATURES

- Quick Detachable Handle for Easy Transport
- Patented Infinite Position Handle Height Adjustment
- Super-Flex Switch Levers
- Safety Switch Lock-Out
- Heavy Duty Transport Wheels
- Triple Planetary, Stainless Steel Gearbox
- 50' Safety Yellow Power Cord 14/3 Ga.

The Betco FL series floor machines are engineered for easy use, operator safety and system performance. All FL series floor machines are CSA safety tested and certified. Built with the highest quality components, Betco floor machines provide outstanding performance and durability. A variety of options including onboard solution tank, poly brush or grit brush make these units versatile to handle all your cleaning jobs.

WARRANTY

3 year (except wear items)*.

10 year unconditional rotationally molded base.

*Please refer to Betco Equipment Price/Product Guide for complete equipment warranty information.

Authorized Betco Distributor:



SPECIFICATIONS

- Pad Speed: 175 RPM
- Motor: 1 hp AC 1 capacitor
- Amp Draw: 14 amps
- Cord: 50' Safety Yellow 14/3 Ga.
- Plug: Hospital Approved 3 prong
- Noise Level: 57 dB
- Weight: 85 lbs.
- CSA Tested and Certified

APPLICATIONS

- Stripping
- Scrubbing
- Spray Buffing
- Bonnet and Brush Carpet Cleaning

OPTIONS

Chemical Solutions Tank: Item #85085

Pad Holder: Item #85076

Poly Scrub Brush: Item #87012

Grit Scrub Brush: Item #87014

Nylon Carpet Brush: Item #87013

Better Resources. Better Results.



BETCO BETTER SOLUTIONS

OFFERING THE TOTAL SOLUTION.

Betco is now the only manufacturer with a complete line of products for the cleaning professional.



Complete Floor Machine, Vacuum and Scrubber Line.



Complete Carpet Care Program.

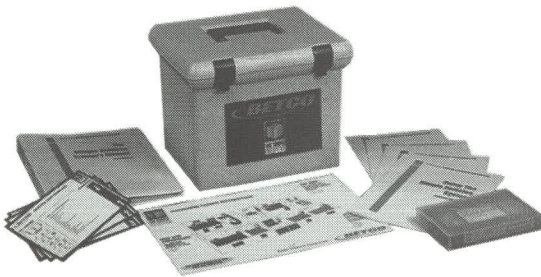

Complete Training Programs.



Complete Chemical Programs, Cleaners, Floor Care and specialties.



Complete Hand Cleaner Line.

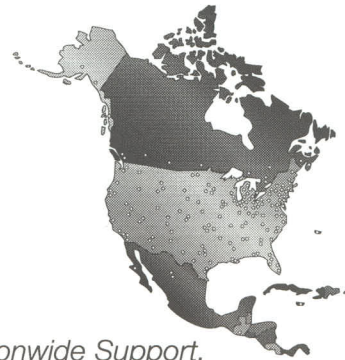

Nationwide Support.

Let Betco be your single source manufacturer.

Better Resources. Better Results.
BETCO®

Floor Machines

Parts Schematic



FL17
FL19

Item #85009
Item #85010

Better Resources. Better Results.
BETCO[®]

BETCO BETCO TX SS 19"/17"

85010R /
85009R

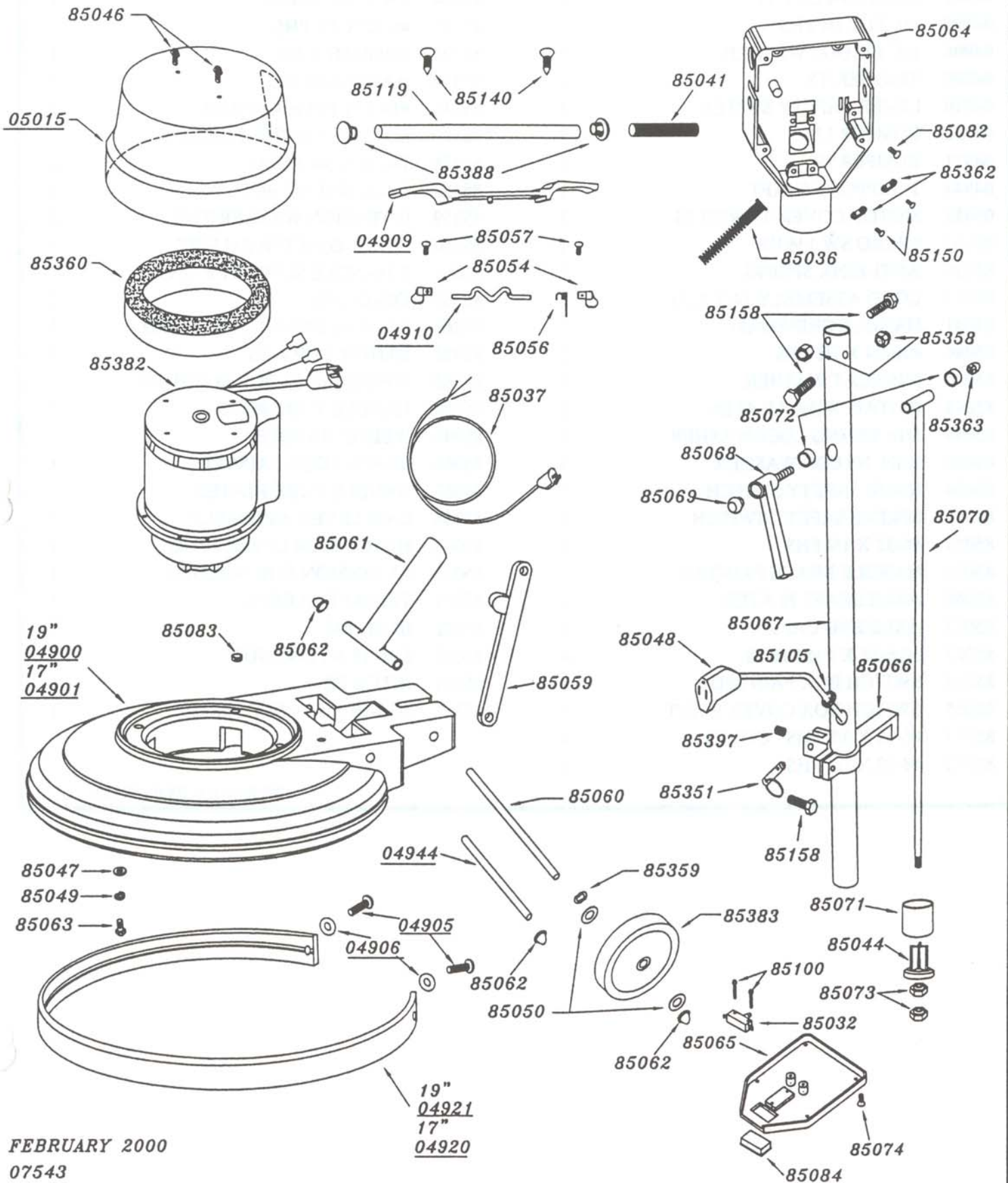

ITEM	DESCRIPTION	QTY	ITEM	DESCRIPTION	QTY
04900	CHASSIS-POLY 19"	1	85083	PLUG	1
04901	CHASSIS-POLY 17"	1	85084	SWITCH INSERT	1
04905	1/4-20 X 3/4 PHS	2	85100	#6-32 X 7/8 PHS	2
04906	1/4" LG DIA. WASHER	2	85105	GROMMET 3/8"	1
04909	TRIGGER TX	1	85119	HANDLE TUBE	1
04910	LEVER SAFETY SWITCH	1	85140	#14-1 1/2 TYPE A SCREW	2
04920	BUMPER 17"	1	85150	8-32 X 1/2 TAPTITE PHILLIPS	4
04921	BUMPER 19"	1	85158	1/4-20 X 3/4 HHMS	2
04944	T-SUPPORT SHAFT	1	85358	1/4-20 NYLOC NUT	3
05015	MOTOR COVER-TX RED SS	1	85359	1/2 TENSION WASHER TW8	2
85032	MICRO SW 1 1/2 HP	1	85360	SHROUD FILTER SM WET	1
85036	ANTI-KINK SPRING	1	85061	T-HANDLE SUPPORT PAINT	1
85037	CORD ASSEMBLY 14/3 X 50'	1	85362	CORD GRIP	2
85041	HANDLE GRIP FOAM	2	85363	3/8-16 ACORN NUT FLANGED	1
85046	#10-24 X 1/2 PHS	2	85382	MOTOR 1 HP - SS	1
85047	5/16 FLAT WASHER	4	85383	WHEEL 5in. FLOOR MACHINE	2
85048	PIGTAIL FEMALE 42 IN.	1	85388	HANDLE TUBE PLUG	2
85049	5/16 SPRING LOCKWASHER	4	85044	WEDGE HANDLE	1
85050	1/2 IN. NYLON WASHER	4	85066	BRACE LOCK PAINTED	1
85054	KNOB SAFETY SWITCH	2	85067	HANDLE TUBE PLATED	1
85056	SPRING SAFETY SWITCH	1	85068	CAM LEVER ASSEMBLY	1
85057	#6-32 X 1/4 PHS	2	85069	HEYCO CAM LEVER PLUG	1
85059	HANDLE BRACE PAINTED	1	85070	EXTENSION ROD WELDED	1
85060	AXLE SHAFT PLATED	2	85071	TAPERED SLEEVE	1
85062	AXLE END CAPS	4	85072	BUSHING	2
85063	5/16-18 X 1 1/2 HHMS	4	85073	5/16-18 NYLOC NUT	2
85064	SWITCH BOX PAINTED	1	85351	HITCH PIN	1
85065	SWITCH BOX COVER PAINT	1	85397	5/16-18 X 5/16 SET SCREW	1
85074	#6-32 X 3/8 FHS - COVER	4			
85082	#8-32 X 1/4 PHS	1			

Floor Machines

Operator's Manual



FL17	Item #85009
FL19	Item #85010
FL17HD	Item #85018
FL19HD	Item #85019
FL17DS	Item #85011
FL19DS	Item #85012

Better Resources. Better Results.
BETCO[®]

INTRODUCTION

This manual will help you get the most from your Betco Floor Machine. Read it thoroughly before operating.

The Betco Floor Machine is intended for commercial use.

PARTS & SERVICE:

Contact your BETCO AUTHORIZED DISTRIBUTOR for repair parts or service. Please specify the Model & Serial Number when discussing your machine.

NAME PLATE:

The Model & Serial Number of your machine is located on the Name Plate on the back of the handle assembly. This information is often needed when ordering repair parts for the machine.

IMPORTANT SAFETY INSTRUCTIONS

When using an electrical appliance, basic precautions should always be followed, including the following:
Read all instructions before using.

! WARNING!

To reduce risk of fire, electric shock, or injury:

- * Do not leave the machine when it is plugged in. Unplug the unit from the outlet when not in use & before servicing.
- * To avoid electric shock, do not expose machine to rain. Store indoors.
- * Do not allow to be used as a toy. Close attention is necessary when used by or near children.
- * Use only as described in this manual. Use only manufacturer's recommended attachments.
- * Do not use with damaged cord or plug. If machine is not working as it should return it to a service center for inspection.

- * Do not pull or carry by cord, use cord as a handle, close a door on a cord, or pull cord around sharp edges or corners. Do not run machine over cord. Keep cord away from heated surfaces.
- * Do not unplug by pulling on cord. To unplug, grasp the plug, not the cord.
- * Do not handle plug or machine with wet hands.
- * Do not put any foreign object into openings. Do not use with any opening blocked; keep free of dust, lint, hair, & anything that may reduce airflow.
- * Keep hair, loose clothing, fingers, & all parts of body away from openings & moving parts.
- * Turn off all controls before unplugging.
- * Do not use in or around flammable or combustible liquids such as gasoline or use in areas where they may be present.
- * Connect to a properly grounded outlet only. See grounding instructions.

GROUNDING INSTRUCTIONS

This machine must be grounded. If it should electrically malfunction, grounding provides a path of least resistance for electric current to reduce the risk of electric shock. This machine is equipped with a cord having an equipment-grounding conductor & grounding plug. The plug must be plugged into an appropriate outlet that is properly installed & grounded in accordance with all local codes & ordinances.

! DANGER!

Improper connection of the equipment-grounding conductor can result in a risk of electric shock. Check with a qualified electrician or service person if you are in doubt as to whether the outlet is properly grounded. Do not modify the plug provided with the machine. If plug will not fit the outlet, have a proper outlet installed by a qualified electrician.

Replace the plug if the grounding pin is damaged or broken.

Extension cords connected to this machine should be 12 gauge, 3-wire cords with 3-prong plugs & outlets. DO NOT use extension cords more than 50 feet long.

PREPARING THE MACHINE FOR OPERATION

! WARNING!

This machine contains moving parts. To reduce the risk of injury, always unplug the power cord before servicing.

With the handle locked in the upright position, tip the entire machine backward, resting on handle assembly.

Align the proper pad on the pad drive assembly, secure with locking plate, hand tight only.

! CAUTION!

Use the proper pad for each cleaning procedure.

Unwrap the power cord completely & plug into a properly grounded outlet.

Adjust the handle to a comfortable position. This adjustment will vary from operator to operator.

Be prepared to control the machine as soon as you release the safety lock tab & pull either switch lever.

Immediately start moving forward. Keep the machine moving while the motor is running.

Note: When the dual controlled switch levers are released, the machine shuts off immediately.

PROCEDURE'S

SPRAY BUFFING

Lightly spray floor area to be buffed. (3 or 4 passes will restore appearance level)

SCRUBBING

Mop floor with properly diluted cleaner.

Allow for proper dwell time.

Wearing protective anti slip boots/shoes operate the floor machine in a side to side motion until surface is cleaned to desired level.

Floors will require scrubbing & recoating periodically depending on wear & use.

AFTER USE

Return handle assembly to the upright, locked position.

Unplug the power cord, starting from the machine wrap the power cord onto the handle assembly.

With the machine in the upright, locked position, tip the entire machine backward, resting on the handle assembly.

Remove the pad holder from the machine. (Clean pads)

Wipe the entire machine with a clean, damp cloth.

Inspect the machine & all accessories for damage. Perform any required maintenance or repairs before storage.

Store the machine in a clean, dry place with the handle in the upright, locked position.