



E83009-00

E83013-00

E83010-00

E83014-00



FOREMAN[®] 17DS
FOREMAN[®] 20DS

CREWMAN[™] 17HD
CREWMAN[™] 20HD

17", 20"
Floor Machines



**Operator and Parts
Manual**

Specifications

Length – 24.25 in.

Width – 20. in.

Height – 48 in.

Weight – 85.5 Lbs.

Speed 175 Std, Two Speed 185/330

Pad Diameter 17 or 20 in. Drivers 16” & 19”

Drive motor – 1.5 HP, 120v, 12A, 60 Hz
- 1 HP, 120v, 12A, 60 Hz
Two Speed – 1.5 HP, 12 A, 60 Hz

Cord – 14-3 ST, 50 ft.

Hour meter – 0.1 hr resolution

Safety

Read and understand the manual before operating this machine.

Do not operate in explosive areas or use near flammable liquids or gases or dust.

Attach only to properly grounded outlet.

Do not expose to rain, store indoors.

Do not operate the machine with a damaged cord or plug.

Do not block or disconnect the safety lever.

Do not leave the machine plugged in while unattended.

Unplug the machine before servicing.

Do not put fingers under the pad or pad holder.

Unplug the machine before installing or removing the pad.

Use only with Suitable Pads or Brushes.

Warning - This product contains a chemical known to the State of California to cause cancer.

Operating Instructions

Check machine for damage to cord or plug.

Use suitable pads or brushes.

To install or change the pad:

1. Unplug the machine.
2. Tip the machine back on the wheels.
3. Install brush or pad driver.
4. Center the pad on the pad driver.

To operate the machine:

1. Plug into a grounded outlet.
2. Release the handle and lower it.
3. The handle should be locked into a comfortable position for the operator.
4. Press the safety lever and squeeze the trigger to start the machine.
5. Do not operate in one place as damage to the floor or finish could result.
6. Do not operate the machine with the handle in the upright position.
7. Remove the pad after every use.
8. Store the machine with the pad or brush removed.
9. Use only new or clean pads and reverse them as needed.

Maintenance

To maintain appearance – wipe the machine with a damp cloth after use.

Warning – Unplug the machine before servicing

This machine is equipped with an hour meter to signal maintenance intervals of 250 hours. It will begin flashing at 245 hrs and stop at 255 hrs to signal the operator to check the following:

1. Check the motor brushes for wear or excessive arcing on the two speed machine.
2. Check the cord and electrical system.
3. Check the safety lockout on the trigger.
4. Check the wheels.

ELECTRICAL

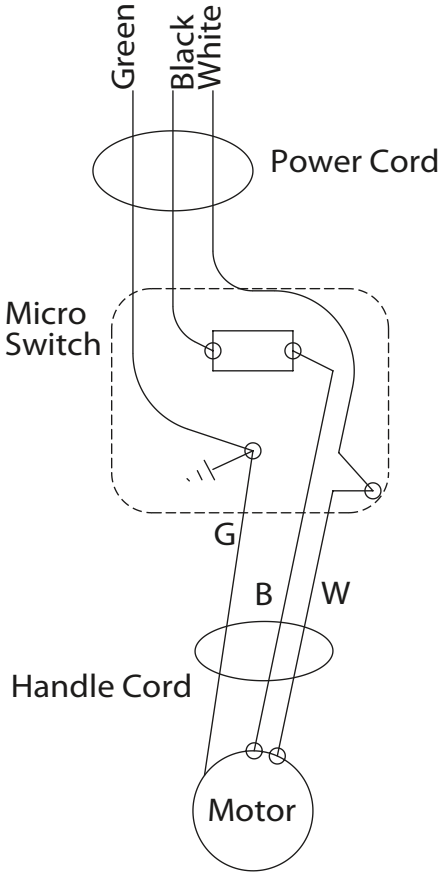

Standard Machines

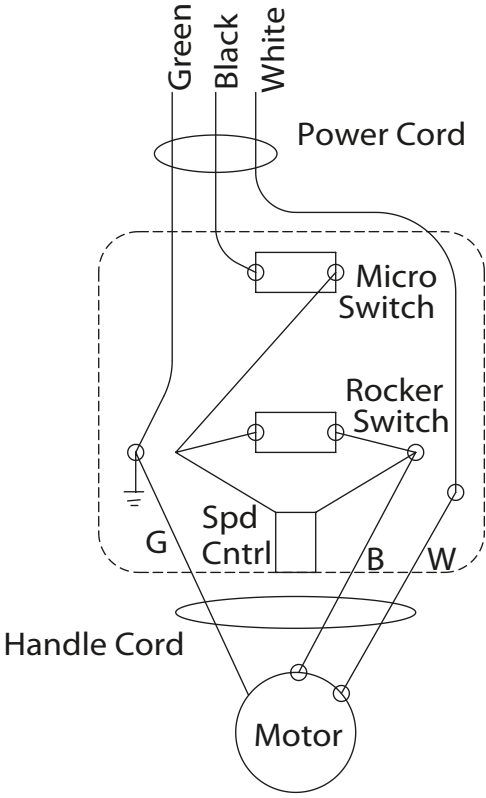

Two Speed Machines

CREWMAN HD HANDLE ASSEMBLY BEFORE SERIAL NUMBER 0438426

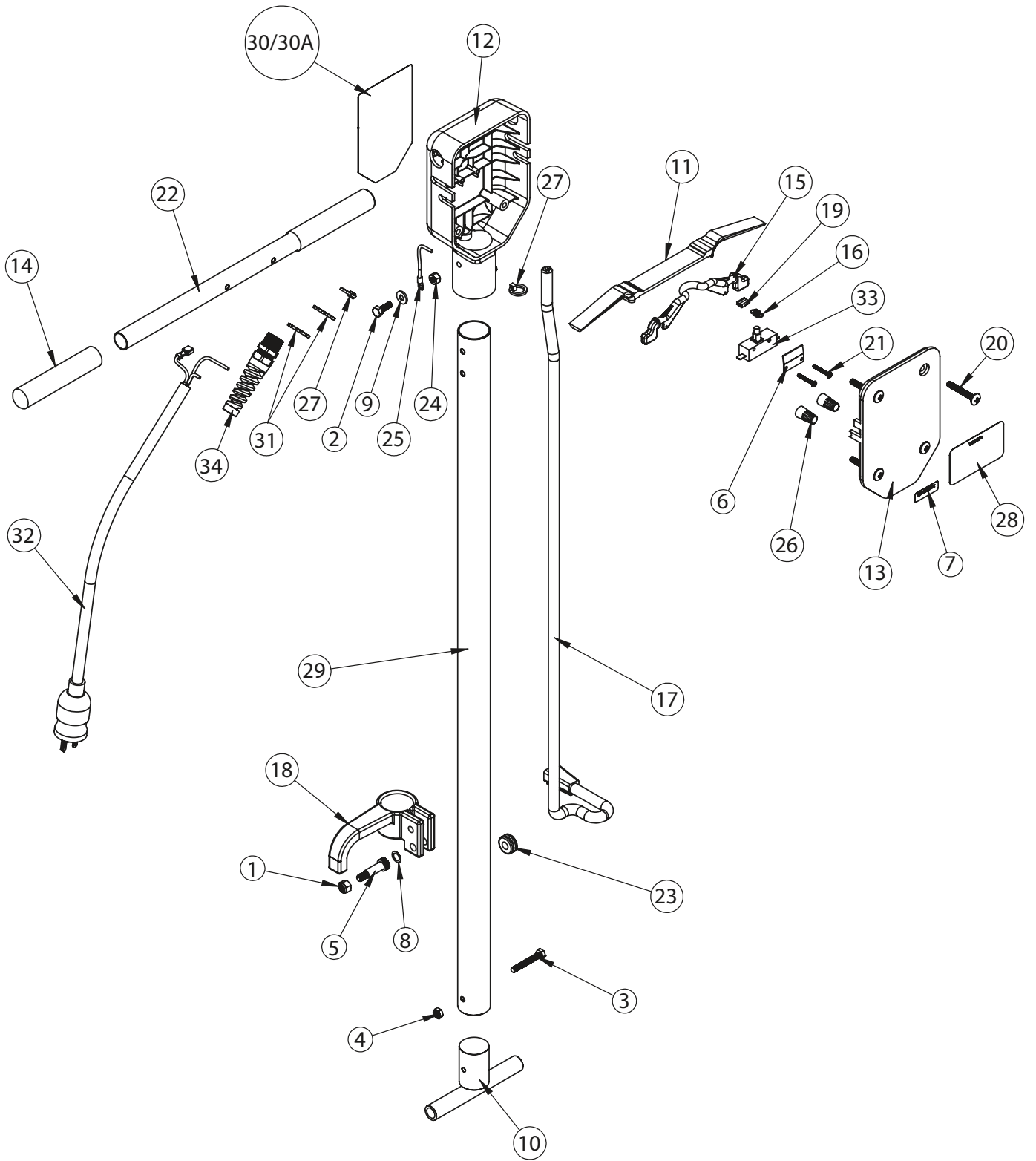

CREWMAN HD HANDLE PARTS BEFORE SERIAL NUMBER 0438426

ITEM NO.	PART NUMBER	DESCRIPTION	QTY.
1	E81063	Nyloc Hex Nut 5/16-18 Zinc	1
2	E81064	Hex Bolt 1/4-20 x 0.75 Lg Zinc	2
3	E81065	Hex Hd Bolt, 1/4-20 x 1-3/4 Lg, Zinc	1
4	E81070	Thin Nyloc Nut, 1/4-20, Zinc	1
5	E81077	Shoulder Screw, 5/16-18, 3/8 x 1	1
6	E81105	Plate, Switch	1
7	E81180	Serial Decal	1
8	E81379	Spring Washer, 0.375 Crescent	1
9	E81713	Flat Washer 0.250 Zinc	2
10	E82717	Handle Socket	1
11	E82749	Handle Trigger Switchbox	1
12	E82750	Switch Box, Handle, Black	1
13	E82751	Cover, Switchbox	1
14	E83127	Handle Grip 7/8 ID	2
15	E83129	Safety Lock	1
16	E83130	Spring, Extension	1
17	E83132	Handle Cord 14-3	1
18	E83137	Handle Lock Cord Hook	1
19	E83270	Spring Clip	1
20	E83426	Round Screw, 1/4-20 x 1.750 Lg	4
21	E83427	Screw 6-32 x 1.00 Lg	2
22	E83451	Handle Grip Tube	1
23	E83519	Grommet, 1/8 W x 5/8 Groove	1
24	E83520	Nyloc Hex Nut 1/4-20 Zinc	2
25	E83521	Green Ground Wire, Swing Machine	1
26	E83522	Wire Nut, Yellow	2
27	E83523	Cable Tie 4.125 Lg x 0.125 W	2
28	E83691	Decal, Warning	1
29	E83711	Main Handle Tube	1
30	E83723	Decal, Betco Crewman 20HD	1
31	E83789	Strain Relief Nut, Metal	2
32	E83790	Cord, 14-3 x 50 ft STW Yellow	1
33	E85032	Switch, 25 AMP, 1/5 HP, 125 VAC	1
34	E89602	Cord Strain Relief, Metal	1

EP50064 - CAM LOCK ASSEMBLY

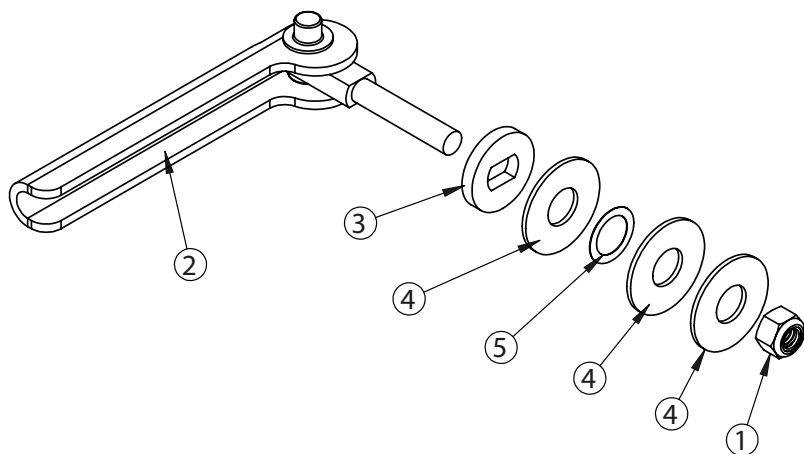

ITEM NO.	PART NUMBER	DESCRIPTION	QTY.
1	E81063	Nyloc Hex Nut 5/16-18 Zinc	1
2	E83133	Cam Lock Handle	1
3	E83135	Oval Washer	1
4	E83145	Nylon Washer 1/2 ID x 1.25 OD	3
5	E83269	Spring Washer 1/2 ID	1

CREWMAN HD HANDLE ASSEMBLY AFTER SERIAL NUMBER 0438426

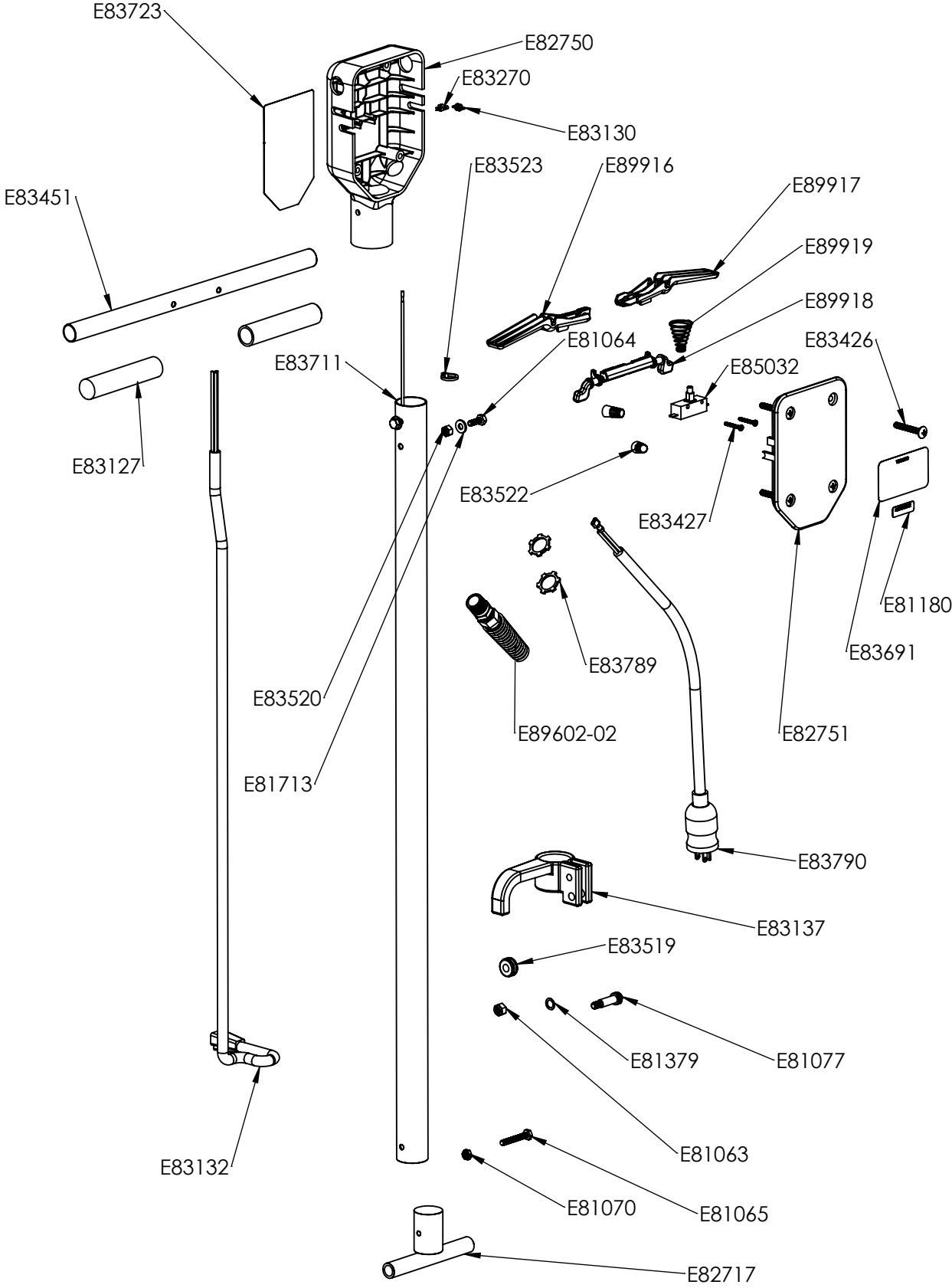

CREWMAN HD HANDLE PARTS AFTER SERIAL NUMBER 0438426

ITEM NO.	PART NUMBER	DESCRIPTION	QTY.
1	E81063	Nyloc Hex Nut 5/16-18 Zinc	1
2	E81064	Hex Bolt 1/4-20 x 0.75 Lg Zinc	2
3	E81065	Hex Hd Bolt, 1/4-20 x 1-3/4 Lg, Zinc	1
4	E81070	Thin Nyloc Nut, 1/4-20, Zinc	1
5	E81077	Shoulder Screw, 5/16-18, 3/8 x 1	1
6	E81180	Serial Decal	1
7	E81379	Spring Washer, 0.375 Crescent	1
8	E81713	Flat Washer 0.250 Zinc	2
9	E82717	Handle Socket	1
10	E82750	Switch Box, Handle, Black	1
11	E82751	Cover, Switchbox	1
12	E83127	Handle Grip 7/8 ID	2
13	E83130	Spring, Extension	2
14	E83132	Handle Cord 14-3	1
15	E83137	Handle Lock Cord Hook	1
16	E83270	Spring Clip	2
17	E83426	Round Screw, 1/4-20 x 1.750 Lg	4
18	E83427	Screw 6-32 x 1.00 Lg	2
19	E83451	Handle Grip Tube	1
20	E83519	Grommet, 1/8 W x 5/8 Groove	1
21	E83520	Nyloc Hex Nut 1/4-20 Zinc	2
22	E83521	Green Ground Wire, Swing Machine	1
23	E83522	Wire Nut, Yellow	2
24	E83523	Cable Tie 4.125 Lg x 0.125 W	1
25	E83608	DS Rocker Switch, Dual Speed	1
26	E83691	Decal, Warning	1
27	E83711	Main Handle Tube	1
28	E83723	Decal, Betco Crewman 20HD	1
29	E83789	Strain Relief Nut, Metal	2
30	E83790	Cord, 14-3 x 50 ft STW Yellow	1
31	E85032	Switch, 25 AMP, 1/5 HP, 125 VAC	1
32	E89602	Cord Strain Relief, Metal	1
33	E89916	Switch Lever	1
34	E89917	Switch Lever	1
35	E89918	Safety Lock	1
36	E89919	Safety Spring	1

EP50064 - CAM LOCK ASSEMBLY

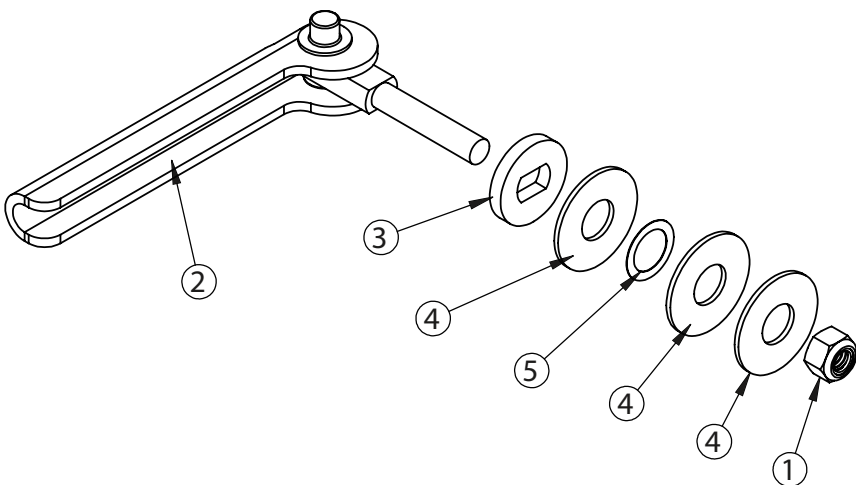

ITEM NO.	PART NUMBER	DESCRIPTION	QTY.
1	E81063	Nyloc Hex Nut 5/16-18 Zinc	1
2	E83133	Cam Lock Handle	1
3	E83135	Oval Washer	1
4	E83145	Nylon Washer 1/2 ID x 1.25 OD	3
5	E83269	Spring Washer 1/2 ID	1

FOREMAN DS HANDLE ASSEMBLY BEFORE SERIAL NUMBER 0438426

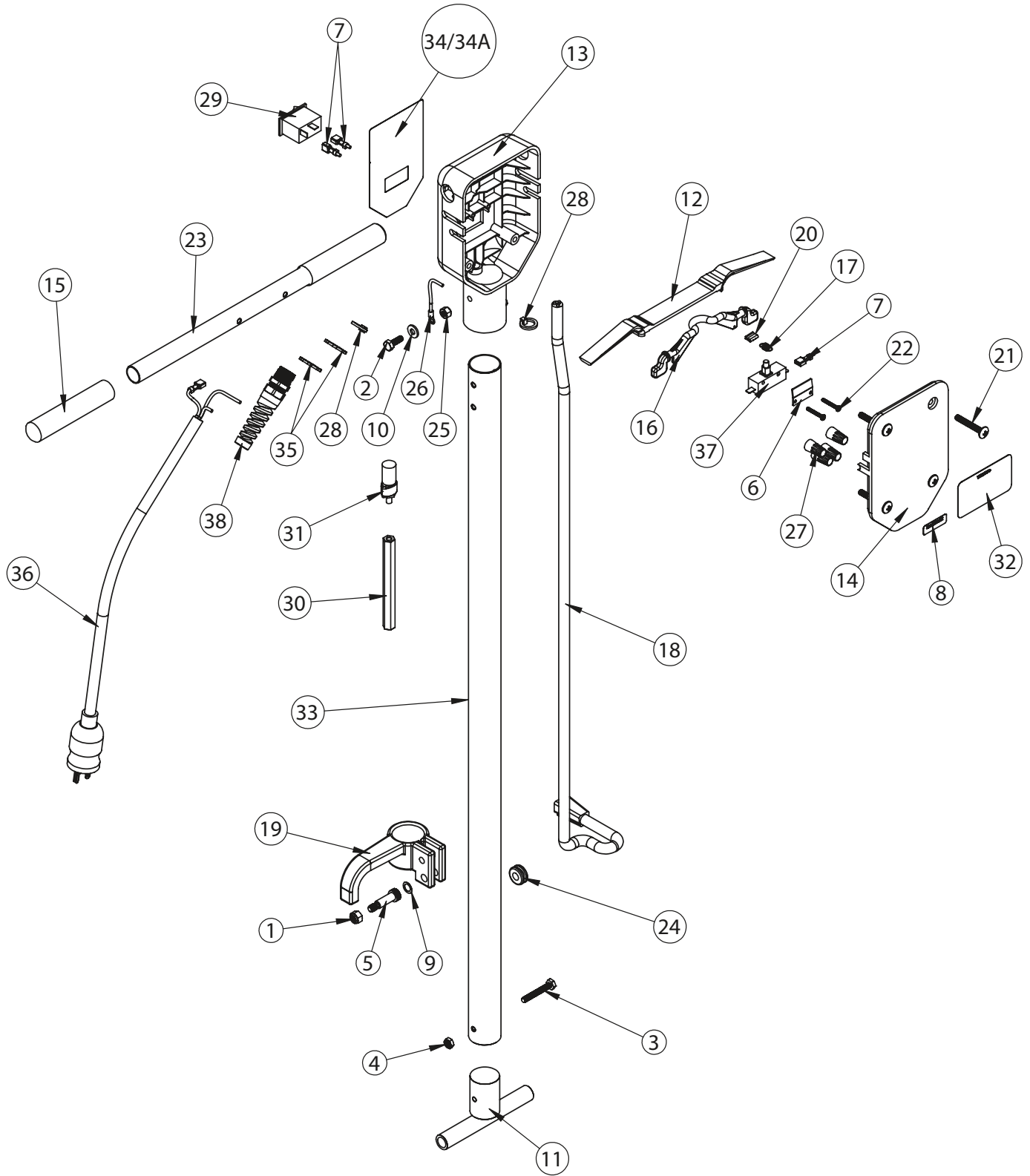

FOREMAN DS HANDLE PARTS BEFORE SERIAL NUMBER 0438426

ITEM NO.	PART NUMBER	DESCRIPTION	QTY.
1	E81063	Nyloc Hex Nut 5/16-18 Zinc	1
2	E81064	Hex Bolt 1/4-20 x 0.75 Lg Zinc	2
3	E81065	Hex Hd Bolt, 1/4-20 x 1-3/4 Lg, Zinc	1
4	E81070	Thin Nyloc Nut, 1/4-20, Zinc	1
5	E81077	Shoulder Screw, 5/16-18, 3/8 x 1	1
6	E81105	Plate, Switch	1
7	E81139	Wire, 16 AWG, Black, 4.00" L, 1 Female QD	3
8	E81180	Serial Decal	1
9	E81379	Spring Washer, 0.375 Crescent	1
10	E81713	Flat Washer 0.250 Zinc	2
11	E82717	Handle Socket	1
12	E82749	Handle Trigger Switchbox	1
13	EP50301	Switchbox Cover, Dual Speed	1
14	E82751	Cover, Switchbox	1
15	E83127	Handle Grip 7/8 ID	2
16	E83129	Safety Lock	1
17	E83130	Spring, Extension	1
18	E83132	Handle Cord 14-3	1
19	E83137	Handle Lock Cord Hook	1
20	E83270	Spring Clip	1
21	E83426	Round Screw, 1/4-20 x 1.750 Lg	4
22	E83427	Screw 6-32 x 1.00 Lg	2
23	E83451	Handle Grip Tube	1
24	E83519	Grommet, 1/8 W x 5/8 Groove	1
25	E83520	Nyloc Hex Nut 1/4-20 Zinc	2
26	E83521	Green Ground Wire, Swing Machine	1
27	E83522	Wire Nut, Yellow	4
28	E83523	Cable Tie 4.125 Lg x 0.125 W	2
29	E83608	DS Rocker Switch, Dual Speed	1
30	E83652	DS Heat Sink Rod	1
31	E83662	Speed Control, Dual Speed Machine	1
32	E83691	Decal, Warning	1
33	E83711	Main Handle Tube	1
34	E83747	Decal, Betco Foreman 20DS	1
35	E83789	Strain Relief Nut, Metal	2
36	E83790	Cord, 14-3 x 50 ft STW Yellow	1
37	E85032	Switch, 25 AMP, 1/5 HP, 125 VAC	1
38	E89602	Cord Strain Relief, Metal	1

EP50064 - CAM LOCK ASSEMBLY

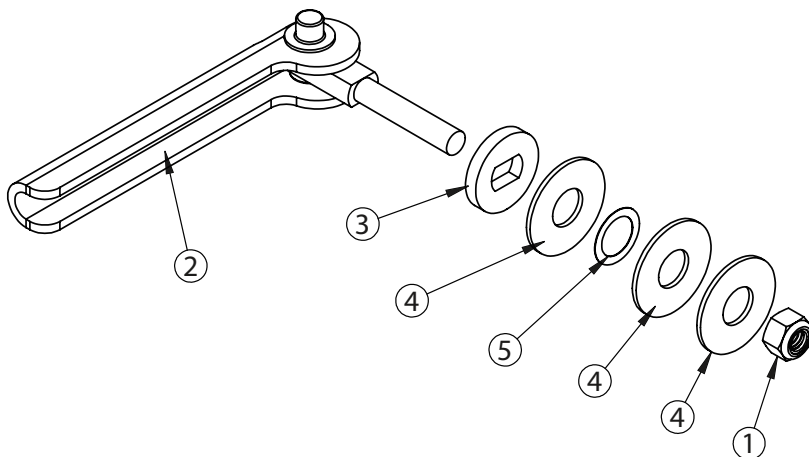

ITEM NO.	PART NUMBER	DESCRIPTION	QTY.
1	E81063	Nyloc Hex Nut 5/16-18 Zinc	1
2	E83133	Cam Lock Handle	1
3	E83135	Oval Washer	1
4	E83145	Nylon Washer 1/2 ID x 1.25 OD	3
5	E83269	Spring Washer 1/2 ID	1

FOREMAN DS HANDLE ASSEMBLY AFTER SERIAL NUMBER 0438426

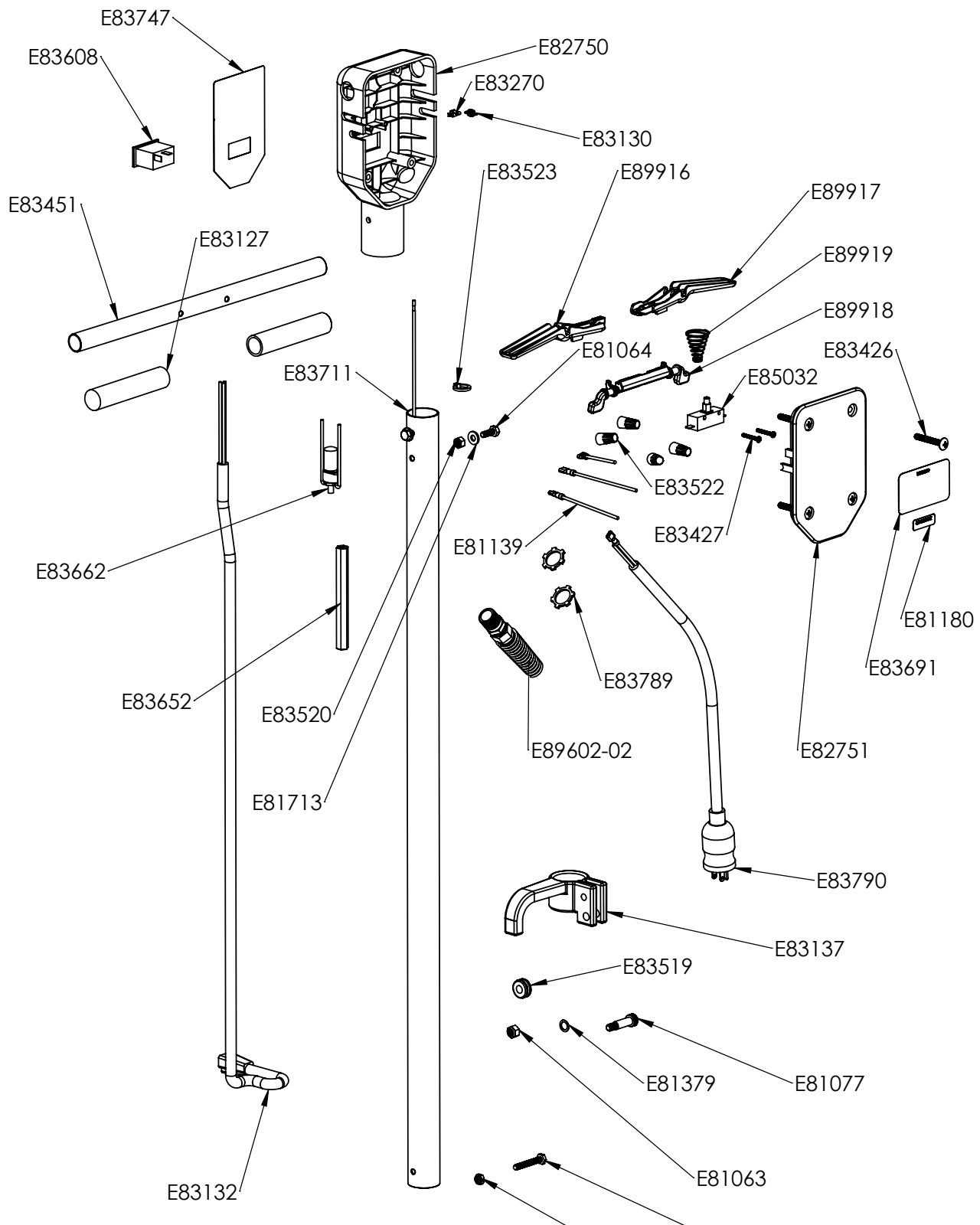

FOREMAN DS HANDLE PARTS AFTER SERIAL NUMBER 0438426

ITEM NO.	PART NUMBER	DESCRIPTION	QTY.
1	E81063	Nyloc Hex Nut 5/16-18 Zinc	1
2	E81064	Hex Bolt 1/4-20 x 0.75 Lg Zinc	2
3	E81065	Hex Hd Bolt, 1/4-20 x 1-3/4 Lg, Zinc	1
4	E81070	Thin Nyloc Nut, 1/4-20, Zinc	1
5	E81077	Shoulder Screw, 5/16-18, 3/8 x 1	1
7	E81139	Wire, 16 AWG, Black, 4.00" L, 1 Female QD	3
8	E81180	Serial Decal	1
9	E81379	Spring Washer, 0.375 Crescent	1
10	E81713	Flat Washer 0.250 Zinc	2
11	E82717	Handle Socket	1
13	E50301	Switchbox Cover, Dual Speed	1
14	E82751	Cover, Switchbox	1
15	E83127	Handle Grip 7/8 ID	2
16	E83130	Spring, Extension	1
18	E83132	Handle Cord 14-3	1
19	E83137	Handle Lock Cord Hook	1
20	E83270	Spring Clip	1
21	E83426	Round Screw, 1/4-20 x 1.750 Lg	4
22	E83427	Screw 6-32 x 1.00 Lg	2
23	E83451	Handle Grip Tube	1
24	E83519	Grommet, 1/8 W x 5/8 Groove	1
25	E83520	Nyloc Hex Nut 1/4-20 Zinc	2
26	E83521	Green Ground Wire, Swing Machine	1
27	E83522	Wire Nut, Yellow	4
28	E83523	Cable Tie 4.125 Lg x 0.125 W	2
29	E83608	DS Rocker Switch, Dual Speed	1
30	E83652	DS Heat Sink Rod	1
31	E83662	Speed Control, Dual Speed Machine	1
32	E83691	Decal, Warning	1
33	E83711	Main Handle Tube	1
34	E83747	Decal, Betco Foreman 20DS	1
35	E83789	Strain Relief Nut, Metal	2
36	E83790	Cord, 14-3 x 50 ft STW Yellow	1
37	E85032	Switch, 25 AMP, 1/5 HP, 125 VAC	1
38	E89602	Cord Strain Relief, Metal	1
37	E89916	Switch Lever	1
38	E89917	Switch Leverl	1
37	E89918	Safety Lock	1
38	E89919	Safety Spring	1

EP50064 - CAM LOCK ASSEMBLY

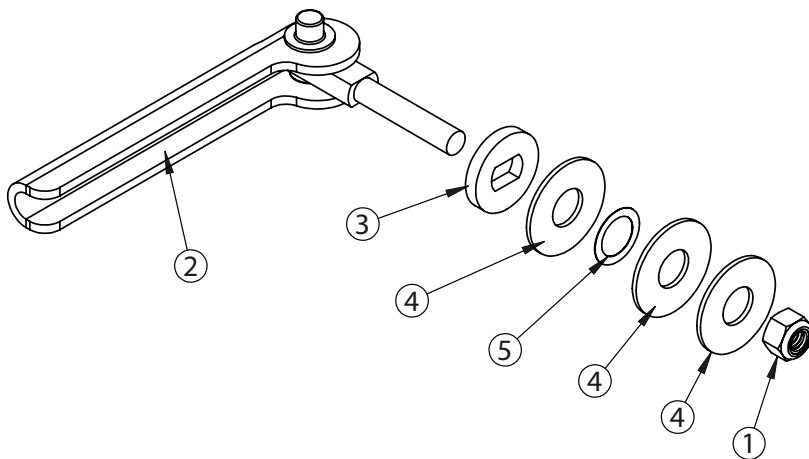

ITEM

NO.	PART NUMBER	DESCRIPTION	QTY.
1	E81063	Nyloc Hex Nut 5/16-18 Zinc	1
2	E83133	Cam Lock Handle	1
3	E83135	Oval Washer	1
4	E83145	Nylon Washer 1/2 ID x 1.25 OD	3
5	E83269	Spring Washer 1/2 ID	1

CREWMAN HD BASE ASSEMBLY BEFORE SERIAL NUMBER 0439909

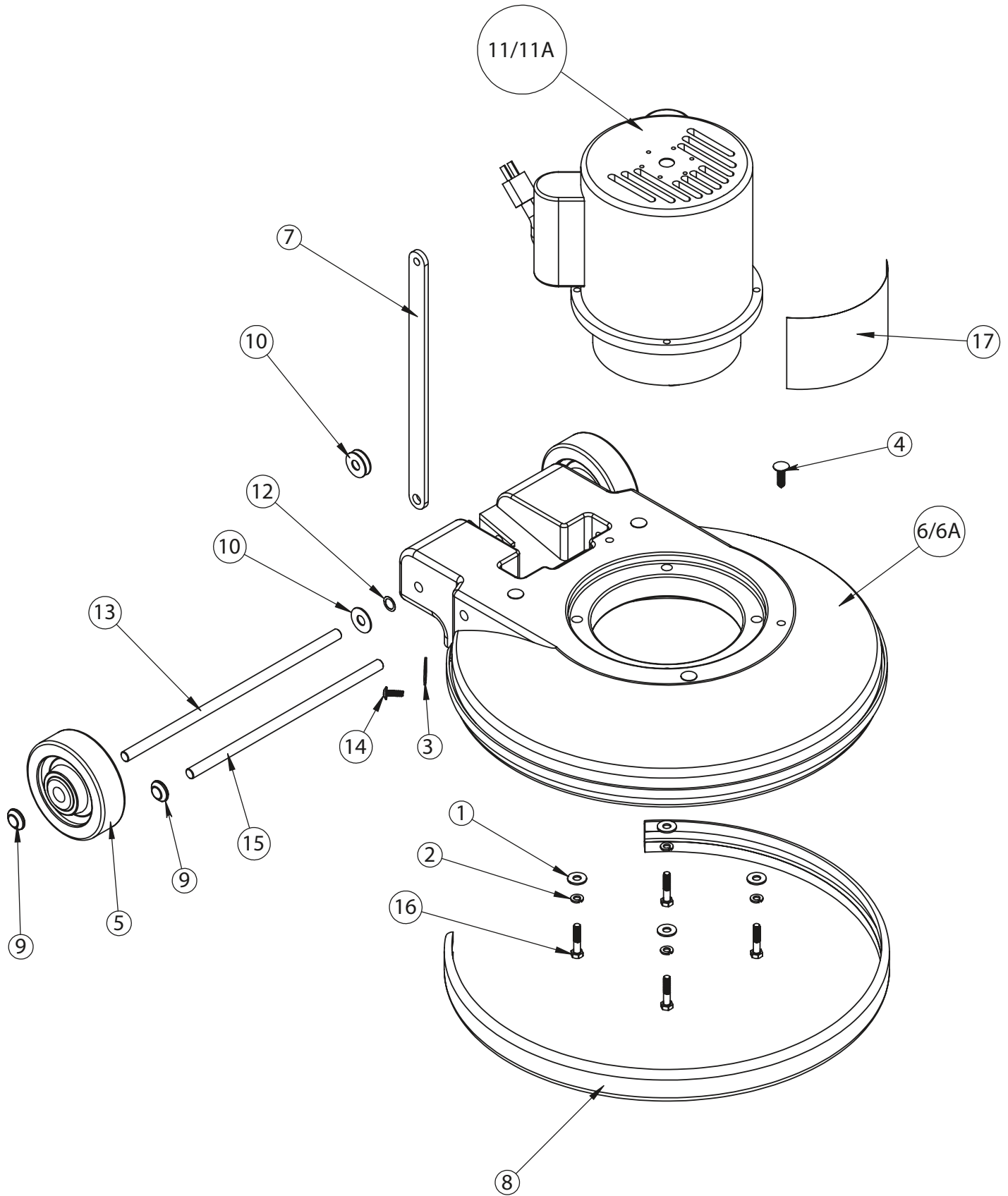

CREWMAN HD BASE PARTS BEFORE SERIAL NUMBER 0439909

ITEM NO.	PART NUMBER	DESCRIPTION	QTY.
1	E81062	Flat Washer 5/16 USS, Zinc	4
2	E81067	Lock Washer 5/16 Zinc	4
3	E81068	Washer, Fender 1/4 Zinc	2
4	E81071	Nylon Rivet, Ribbed Shank 0.281	4
5	E81124	Wheel, 5.00 OD x 3/4 ID	2
6	E81129	Base, 20 in, Low Speed	1
6A	E81127	Base, 17 in, Low Speed	1
7	E83136	Bracket, Flat Handle	1
8	E83141	Bumper 3.5 ft	1
9	E83143	Axle Cap 1/2 in	4
10	E83145	Nylon Washer 1/2 ID x 1.25 OD	4
11	E83191	Motor, 1.5 HP, AC	1
11A	E81106	Motor, 1.5HP-2 Speed Floor Machine	1
12	E83269	Spring Washer 1/2 ID	2
13	E83379	Axle, 0.5 x 13.875	1
14	E83425	Truss Head Screw, 1/4-20 x 3/4 Lg	2
15	E83452	Axle, 0.500 OD x 12.375 Lg, Zinc	1
16	E83641	Hex Hd Bolt, 5/16-18 x 1-1/2 Lg, Zinc	4
17	E83773	Decal, Betco Equipment (for Crewman only)	1

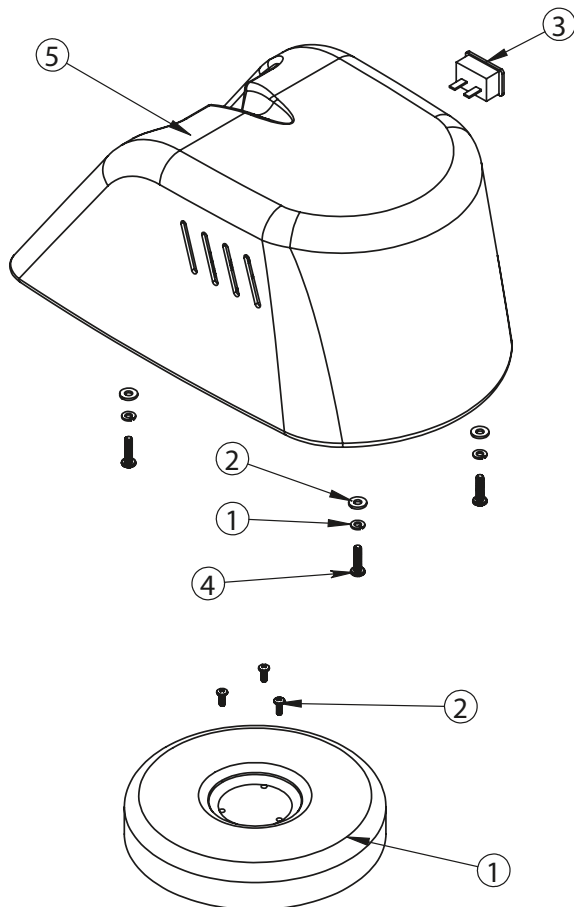

FOREMAN DS COVER

ITEM NO.	PART NUMBER	DESCRIPTION	QTY.
1	E81078	Lock Washer 0.250 Zinc	4
2	E81713	Flat Washer 0.250 Zinc	4
3	E83147	Hour Meter	1
4	E83570	Pan Head Screw 1/4-20 x 1.0 Lg	4
5	E83642	Cover, Motor, Red, Low Speed	1

CREWMAN HD COVER

ITEM NO.	PART NUMBER	DESCRIPTION	QTY.
1	E81140	Cover, Motor, 9 OD x 1.65	1
2	E81526	Screw 10-32 x 1/2, Phillips Trust Head 18-8	3

CREWMAN HD BASE ASSEMBLY AFTER SERIAL NUMBER 0439909

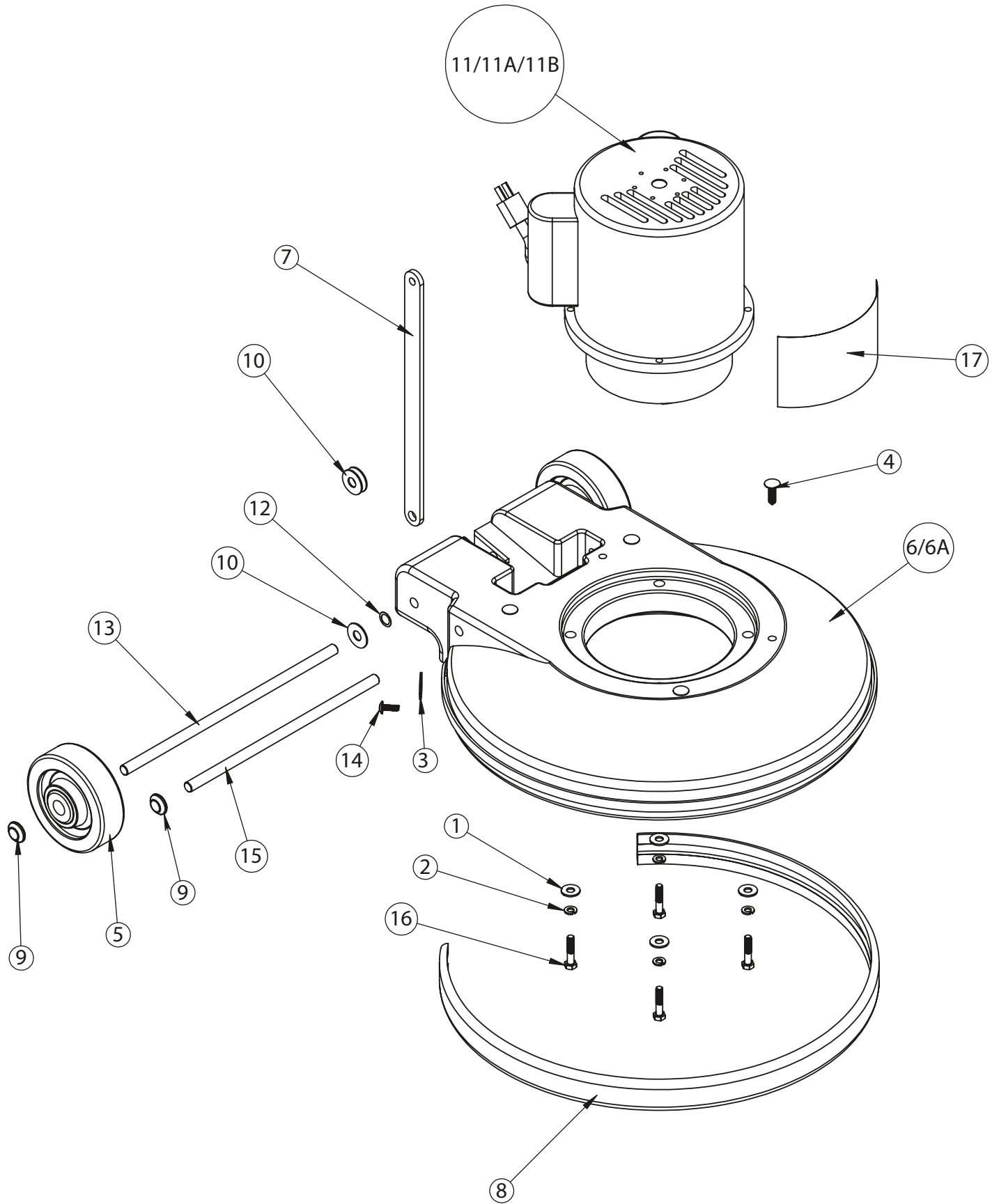

CREWMAN HD BASE PARTS AFTER SERIAL NUMBER 0439909

ITEM NO.	PART NUMBER	DESCRIPTION	QTY.
1	E81062	Flat Washer 5/16 USS, Zinc	4
2	E81067	Lock Washer 5/16 Zinc	4
3	E81068	Washer, Fender 1/4 Zinc	2
4	E81071	Nylon Rivet, Ribbed Shank 0.281	4
5	E81124	Wheel, 5.00 OD x 3/4 ID	2
6	E81129	Base, 20 in, Low Speed	1
6A	E81127	Base, 17 in, Low Speed	1
7	E83136	Bracket, Flat Handle	1
8	E83141	Bumper 3.5 ft	1
9	E83143	Axle Cap 1/2 in	4
10	E83145	Nylon Washer 1/2 ID x 1.25 OD	4
11	E83191	Motor, 1.5 HP, AC	1
11A	E81106	Motor, 1.5HP-2 Speed Floor Machine	1
11B	E84570	Motor, 1.5HP, AC	1
12	E83269	Spring Washer 1/2 ID	2
13	E83379	Axle, 0.5 x 13.875	1
14	E83425	Truss Head Screw, 1/4-20 x 3/4 Lg	2
15	E83452	Axle, 0.500 OD x 12.375 Lg, Zinc	1
16	E83641	Hex Hd Bolt, 5/16-18 x 1-1/2 Lg, Zinc	4
17	E83773	Decal, Betco Equipment (for Crewman only)	1

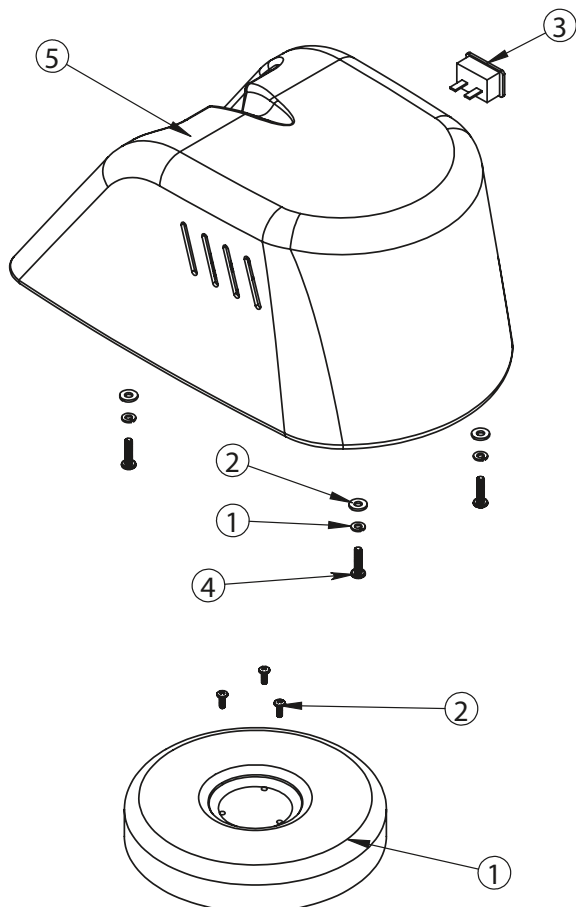

FOREMAN DS COVER

ITEM NO.	PART NUMBER	DESCRIPTION	QTY.
1	E81078	Lock Washer 0.250 Zinc	4
2	E81713	Flat Washer 0.250 Zinc	4
3	E83147	Hour Meter	1
4	E83570	Pan Head Screw 1/4-20 x 1.0 Lg	4
5	E83642	Cover, Motor, Red, Low Speed	1

CREWMAN HD COVER

ITEM NO.	PART NUMBER	DESCRIPTION	QTY.
1	E81140	Cover, Motor, 9 OD x 1.65	1
2	E81526	Screw 10-32 x 1/2, Phillips Trust Head 18-8	3

BETCO US WARRANTY POLICY

10 year coverage

Subject to the conditions stated below, Betco warrants parts and labor on rotationally molded polyethylene tanks/ housings and injection molded vacuum head assemblies to be free from defects in materials and workmanship for a period of ten years to the original purchaser.

3 Year Coverage

Subject to the conditions stated below, Betco warrants parts and labor on all other Betco components to be free from defects in materials and workmanship for a period of three years to the original purchaser.

1 Year Coverage

Subject to the conditions stated below, Betco offers a limited warranty on parts and labor on the following equipment: parts and accessories to be free from defects in materials and workmanship for a period of one year to the original purchaser.

- PowerUp™ 14 Upright Vacuum: #E29990-00
- Bac Pac Lite Vacuum: #85903-00
- FiberPRO® Floor Dryer: #85507-00
- WORKMAN™ Series Vacuums: #85024-00, #85025-00, #83012-00, #85027-00
- All Tools and Accessories
- All Battery Chargers
- All Batteries are pro-rated for 1 year

Allowable Travel Time Warranty Reimbursement:

Eligible equipment: All battery and propane powered equipment products. Warranty period: 90 days from date of sale to the original purchaser. A maximum 180 mile round trip at 50 cents per mile will be allowed for warranty consideration.

Propane Machine Warranty:

Kawasaki engines are warranted by Kawasaki for a period of 2 years against manufacturer defects. All other components (except wear items)* are warranted by Betco for a period of 3 years.

***Wear Items exempt from Warranty consideration include but may not be limited to: power cords, transport wheels, vacuum bags, belts, squeegee blades, pad drivers, clutch plates, handle grips, filters, screens, throttle cables, brushes and carbon brushes.**

Subject to the conditions and exceptions stated in this warranty, Betco warrants the Betco products to be free from defects in material and workmanship, under normal use and service, for the periods listed under the warranty policy to the original purchaser. At any time during the warranty period, Betco will furnish replacement parts for the Betco parts to the original purchaser. Such parts will be furnished and charged including transportation costs, to the original owner through any Betco authorized Service Distributor. If the original part is returned within the warranty policy period from date of delivery for inspection by Betco and is found to be defective the owner will be credited for the cost of replacement parts plus shipping and handling. Replacement parts that have become defective through wear or abuse are not included in this warranty.

This warranty does not apply to damage or defect caused by accident, misuse, negligence, fire, or to any Betco product which has been serviced or repaired by other than an authorized Betco Service Distributor or Betco factory personnel. This warranty is void if products are used for any purpose other than that which was intended. There are no other warranties expressed or implied. In no event shall Betco be liable for incidental or consequential damages or any damage to person or property. (Please note some states do not allow the exclusion or limitations for incidental and consequential damages).

