

Upright Dry Vacuums SM1400T

**Operator's Manual and
Parts Schematic**

Item #85805-00

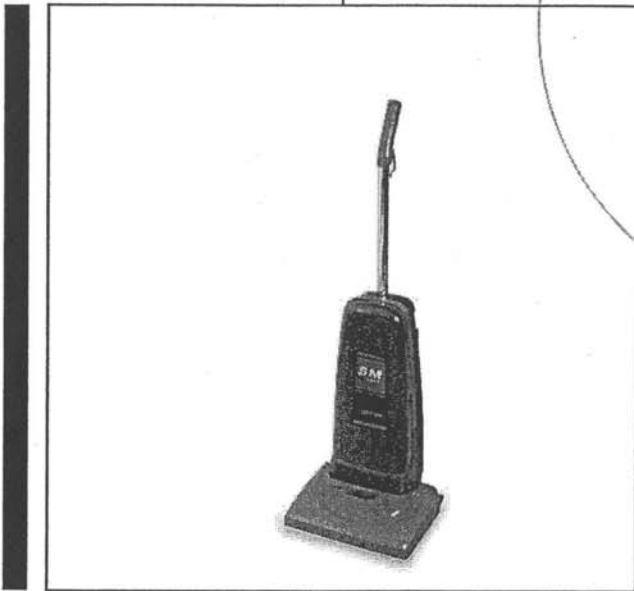

*Chemicals
Equipment
Programs
Process*





WARNING

This service information is designed for experienced repair technicians only and is not designed for use by the general public. It does not contain warnings or cautions to advise non-technical individuals of potential dangers in attempting to service a product. Products powered by electricity should be serviced or repaired only by experienced professional technicians. Any attempt to service or repair the product or products dealt with in this service information by anyone else could result in serious injury or death.

TABLE OF CONTENTS

SPECIFICATIONS	Front Cover
WIRING DIAGRAM AND WIRE MANAGEMENT DRAWING	3
EXPLODED VIEW (GENERAL PARTS)	4
EXPLODED VIEW (NOZZLE HOUSING)	5
PARTS LIST (NOZZLE HOUSING)	6
EXPLODED VIEW (AGITATOR ASSEMBLY)	6
PARTS LIST (AGITATOR ASSEMBLY)	6
EXPLODED VIEW (BODY, MOTOR HOUSING, AND MOTOR)	7
PARTS LIST (BODY, MOTOR HOUSING, AND MOTOR)	8
EXPLODED VIEW (MOTOR FAN ASSEMBLY)	9
PARTS LIST (MOTOR FAN ASSEMBLY)	9
EXPLODED VIEW (PACKING MATERIALS)	10
PARTS LIST (PACKING MATERIALS)	10
COMPONENT REMOVAL CHART	11
LOWER PLATE REMOVAL/INSTALLATION	12
AGITATOR ASSEMBLY REMOVAL/INSTALLATION	12
BRUSH REMOVAL/INSTALLATION	13
BELT REPLACEMENT	13
NOZZLE HOUSING REPLACEMENT	14
SWITCH COVER AREA WIRING MANAGEMENT	15
POWER CORD/ON-OFF SWITCH REPLACEMENT	15-16
MOTOR PROTECTOR REPLACEMENT	16
MOTOR REPLACEMENT	17
CARBON BRUSH REPLACEMENT	17
MOTOR FAN REPLACEMENT	18
TROUBLESHOOTING GUIDE	19

■ PICTORIAL WIRING DIAGRAM

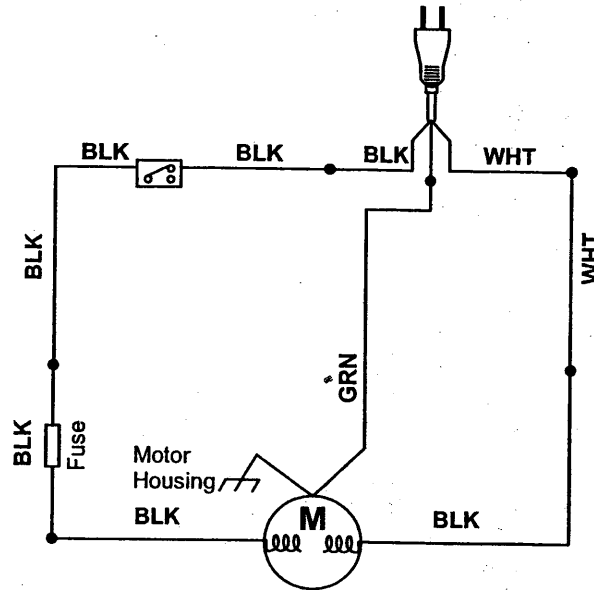

■ WIRING MANAGEMENT DRAWING

NOTE: Do not pinch any wires during reassembly. After servicing any electrical component or electrical enclosure, the unit should be reassembled and checked for dielectric breakdown or current leakage.

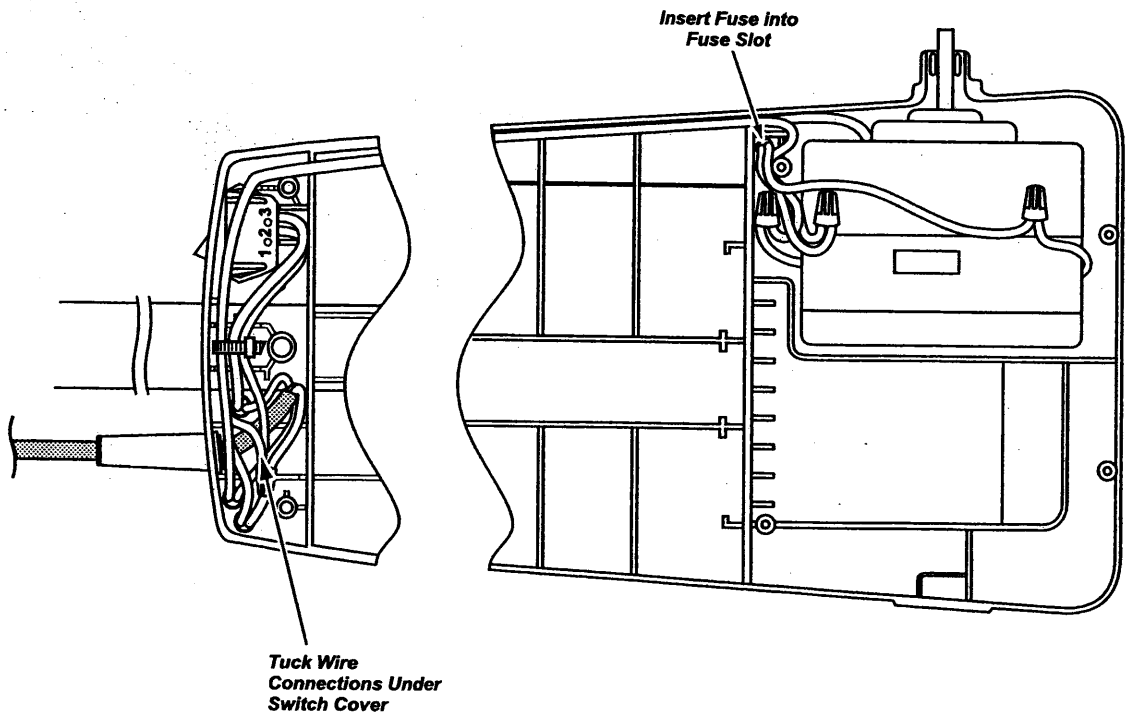

EXPLODED VIEW (GENERAL PARTS)

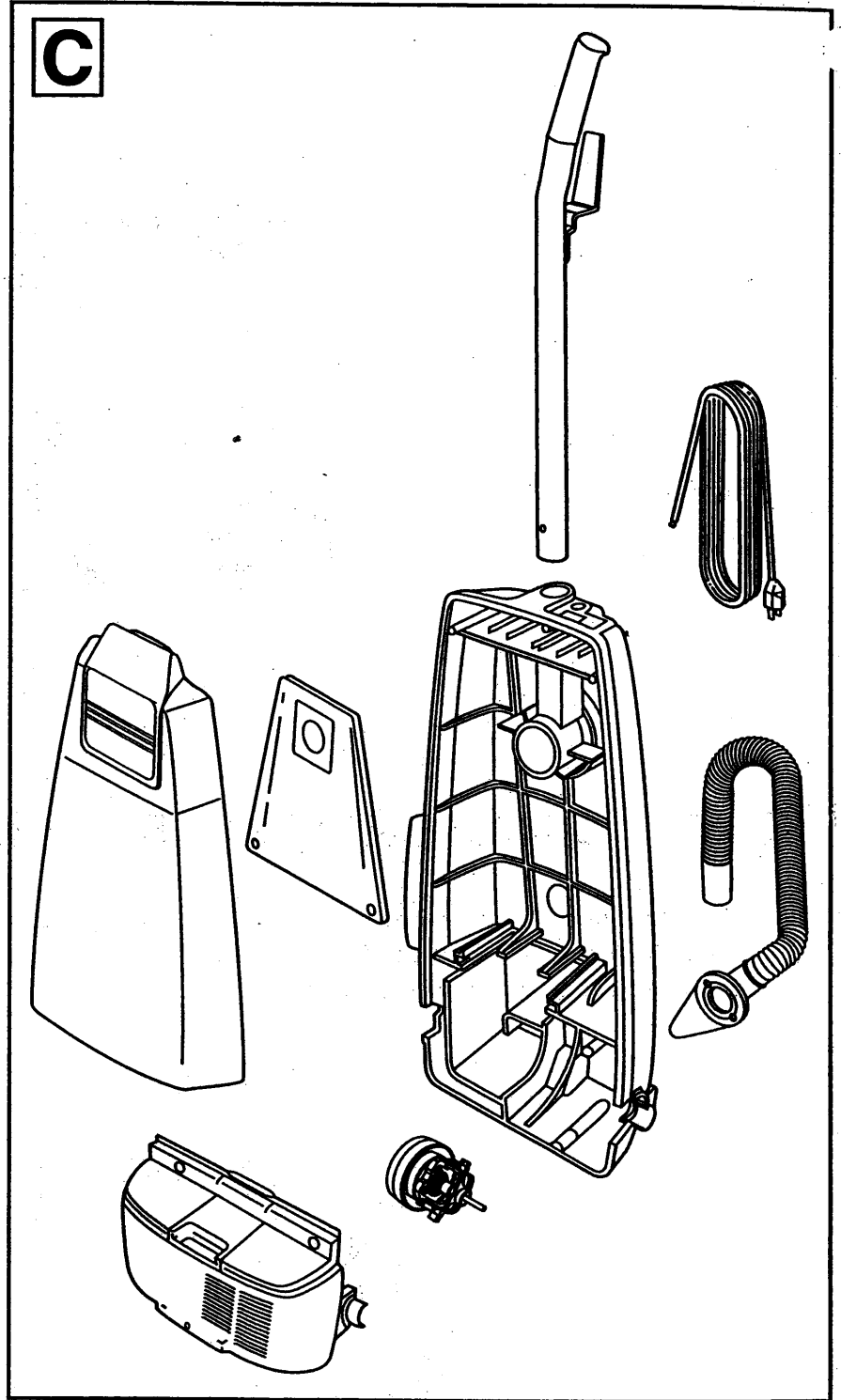
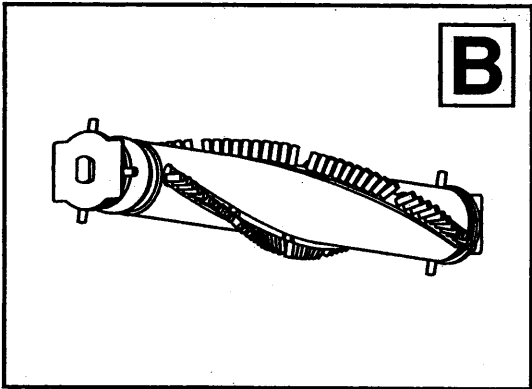
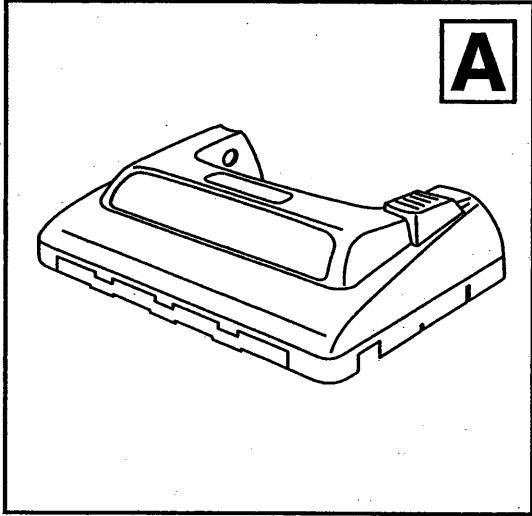

EXPLODED VIEW (NOZZLE HOUSING)... **A** BLOCK

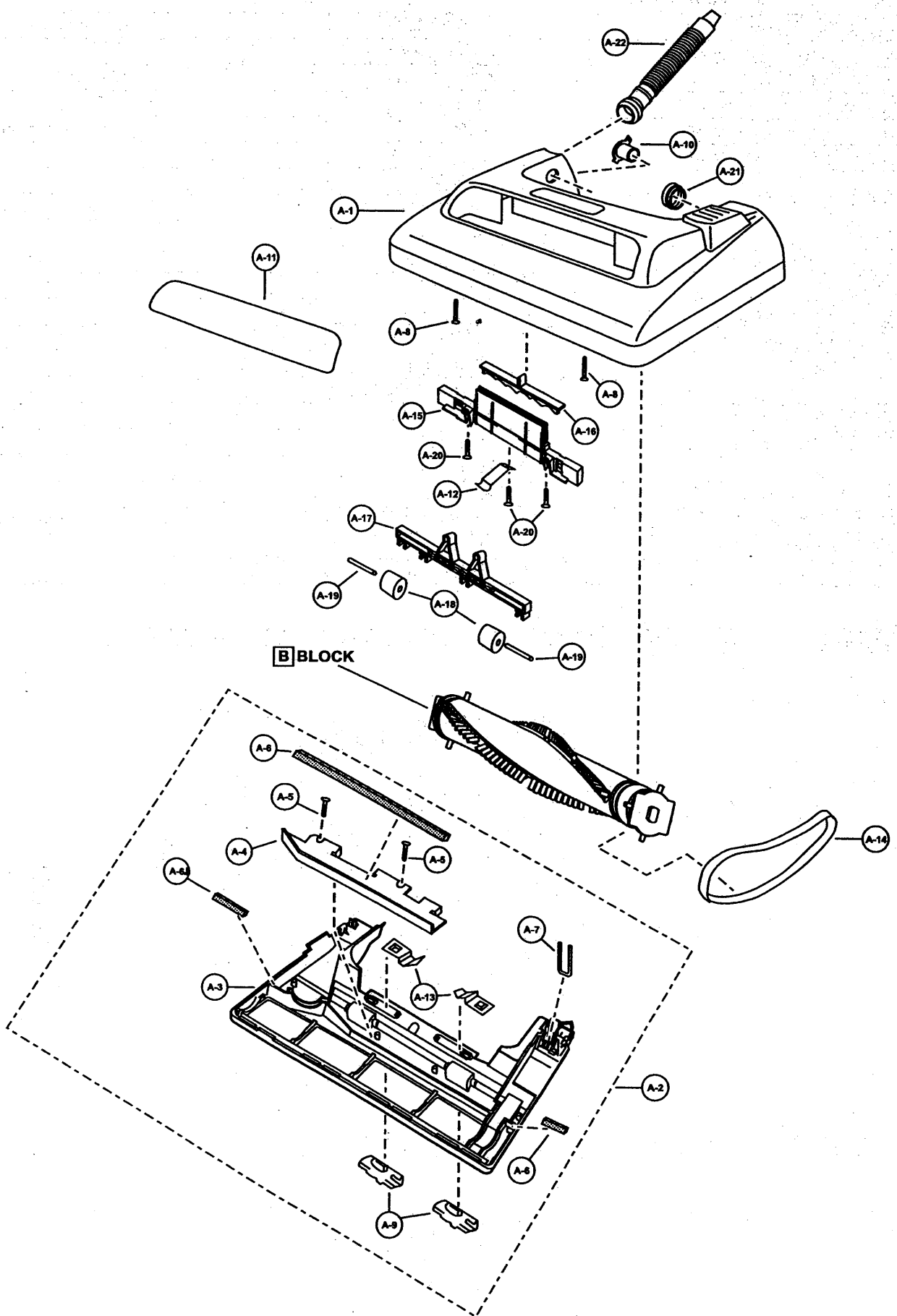

■ PARTS LIST (NOZZLE HOUSING)... [A] BLOCK

Ref. No.	Part Name & Description	Part No.	Quantity	Remarks
A-1	Nozzle Housing	AC01AAZSZV07	1	Furniture Guard Glued On
A-2	Lower Plate Assembly	AC91AAEZZV06	1	
A-3	Lower Plate	AC27AAEZZV06	1	Includes A-6 Packing
A-4	Body, Lower Plate	AC06AAJUZO0	1	
A-5	Screw (Body, Lower Plate)	AXTN4+16BFY	2	Shipped 10 per package
A-6	Packing, Lower Plate	AC19AARKZV00	1	
A-7	Belt Cover	AMC43S-V00	1	
A-8	Screw, Nozzle	AMC68A-V30	2	Shipped 10 per package
A-9	Latch	AMC68N-AV0K	2	
A-10	Plastic Shaft	AMC25S-V00	1	
A-11	Window Cover	AC21HZFZV07	1	
A-12	Pedal Spring	AMC57A-V00	1	
A-13	Stop Latch Spring	AC70NYUZ00	1	
A-14	Belt	AC28SJPZO0	1	
A-15	Slider Support	AC53KAPNZW03	1	
A-16	Sliding Knob	AC57HJPZV06	1	
A-17	Height Adjustment Cam	AC61KJPZV06	1	
A-18	Wheel	AC90QNGZV06	2	
A-19	Shaft (Wheel)	AC16CNXZO0	2	
A-20	Screw (Slider Support, Pedal Spring)	AXTN4+16BFY	3	Shipped 10 per package
A-21	Plastic Holder	AMC78N-V00	1	
A-22	Nozzle Hose	AC34PAJDZV06	1	

■ EXPLODED VIEW (AGITATOR ASSEMBLY)... [B] BLOCK

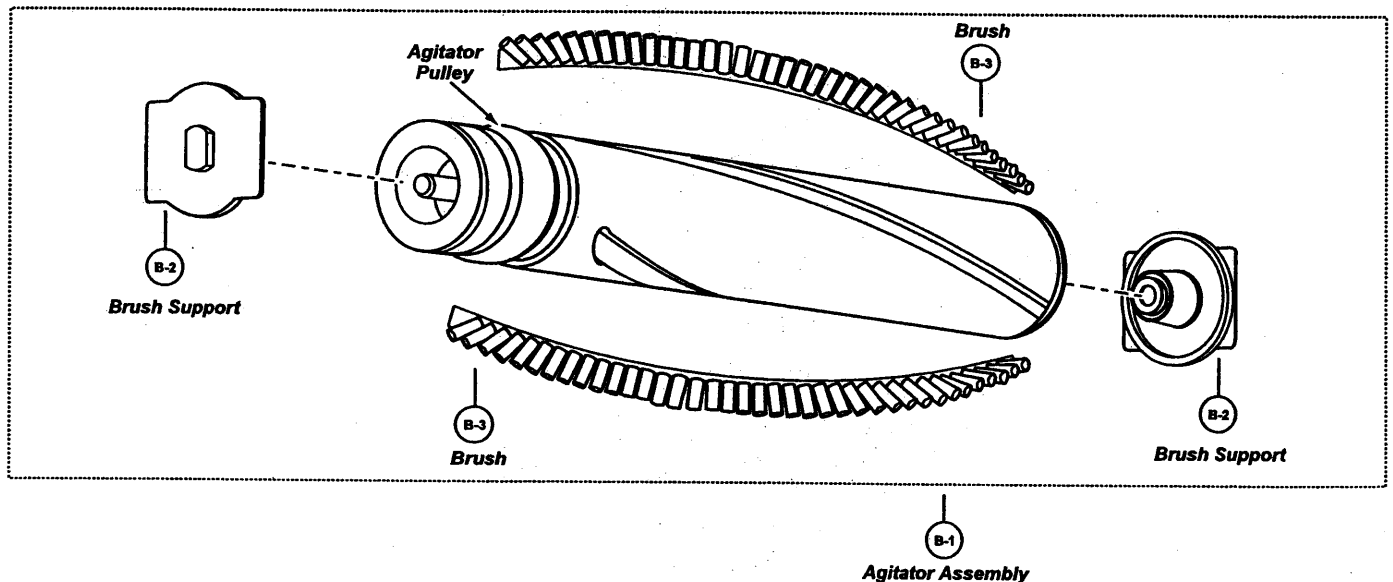

■ PARTS LIST (AGITATOR ASSEMBLY)... [B] BLOCK

Ref. No.	Part Name & Description	Part No.	Quantity	Remarks
B-1	Agitator Unit	AC84RBAXZO00	1	
B-2	End Cap	AC85CTCZO0	2	
B-3	Brush Unit	AC78RBAXZU00	1 (Set)	

EXPLODED VIEW (BODY, MOTOR HOUSING, AND MOTOR)... [C] BLOCK

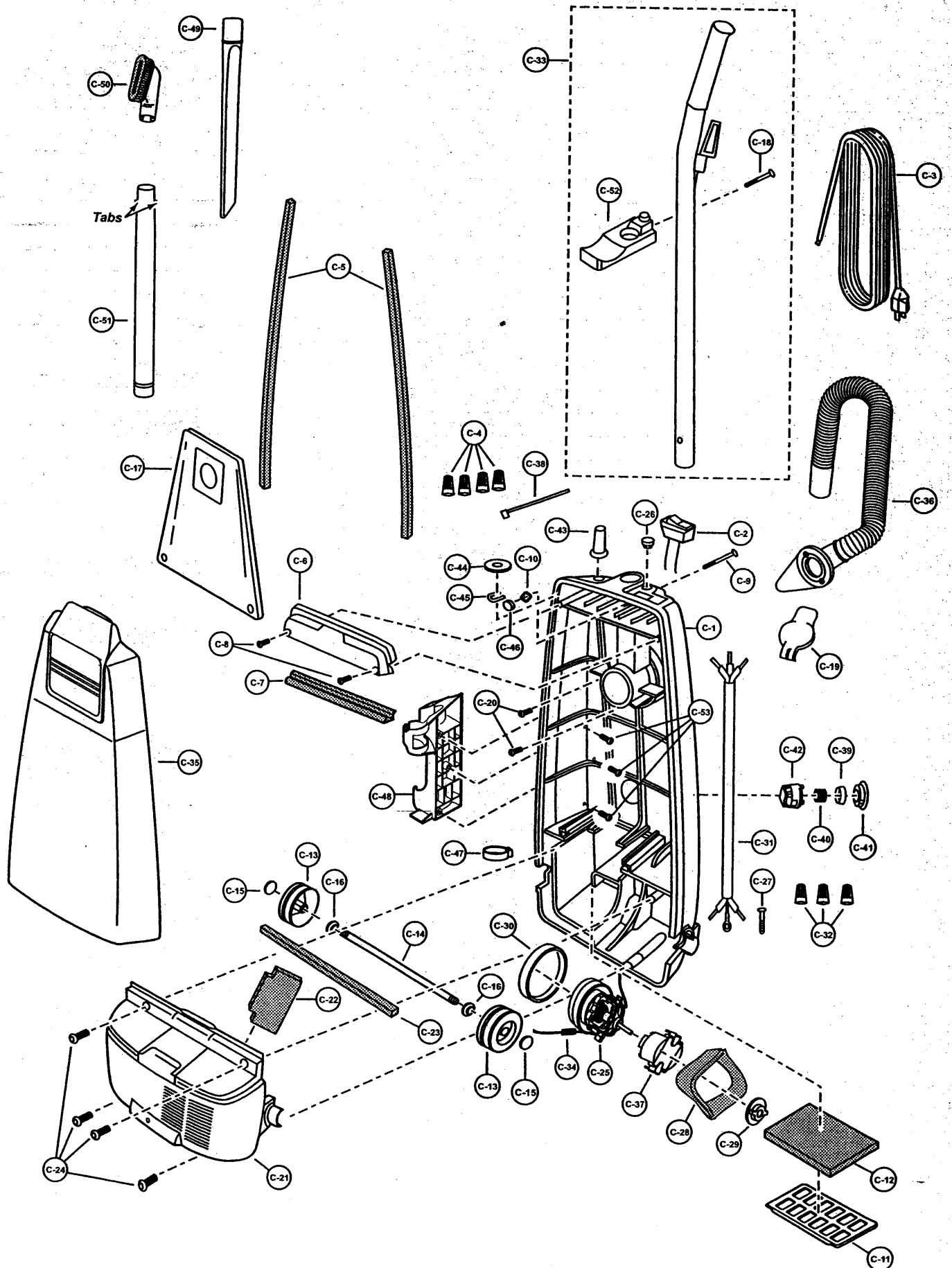

■ PARTS LIST (MOTOR HOUSING, MOTOR, HANDLE, AND BODY)... BLOCK

Ref. No.	Part Name & Description	Part No.	Quantity	Remarks
C - 1	Dust Compartment Unit	AC88KAPNZV17	1	Incl. C-38, C-44, C-45, C-46, C-47 & C-48
C - 2	ON/OFF Switch	AC98EARFZØU	1	Includes C-38 & C-46
C - 3	Power Cord	AC94EAPNZYØ2	1	Incl. C-38, C-44, C-45 & C-46
C - 4	Wire Connector	AMC-1CTCE23	4	Shipped 10 per package
C - 5	Packing (Dust Container)	AC66KVØ1VØ6	2	
C - 6	Switch Cover	ACØ3EARFZVØ6	1	Includes C-46
C - 7	Packing (Switch Cover)	AC73KVØZVØ6	1	
C - 8	Screw (Switch Cover)	AXTN4+16BFY	2	Shipped 10 per package
C - 9	Handle Screw	AMC73B-VØØ	1	
C - 10	Nut (Handle Screw)	AMP21B-17Ø	1	
C - 11	Filter Supporter	AMC32K-VØØ	1	
C - 12	Secondary Filter	AMC37K-VØØ	1	
C - 13	Wheel	AMCØ1C-VØØU	2	
C - 14	Shaft (Wheel)	AC16CUSZØØ	1	
C - 15	Stopper (Wheel)	AC74SUSZØØ	2	
C - 16	Washer (Wheel)	AXWG6E115FY	2	Shipped 10 per package
C - 17	Dust Bag (Type U6)	AC16KCCBZØØØ	1	
C - 18	Screw (Hose Holder)	AXTN4+45BFY	1	Shipped 10 per package
C - 19	Cover (Suction Inlet)	ACØ2HYUZVØ6	1	
C - 20	Screw (Suction Inlet)	AXTN4+16BFY	2	Shipped 10 per package
C - 21	Motor Case	AC99FAPNZVØ7	1	
C - 22	Packing (Rear Cover)	AMCØ2L-VØØ	1	
C - 23	Packing (Motor Case)	AC19FJPZVØ6	1	
C - 24	Screw (Motor Case)	AXTN4+2ØBFY	4	Shipped 10 per package
C - 25	Fan Motor Unit	AC92FAPNZØØ	1	
C - 26	Cover Cap	AC38HAPNZØU	1	
C - 27	Screw, Ground	AXYN4+E1ØFFY	1	Shipped 10 per package
C - 28	Noise Suppressor	AC99GAMMZØØ	1	
C - 29	Motor Support (Rear)	AMCØ3F-VØØ	1	
C - 30	Motor Support Rubber (Front)	AMCØ2F-EØØ	1	
C - 31	Wire Cord	AC37GTEZØU	1	
C - 32	Wire Connector	AMC-1CTCE23	3	Shipped 10 per package
C - 33	Handle Assembly	AC95BATNZVØ7	1	Includes Cord Storage Hook
C - 34	Lead Wire Assembly	AC99WARGZØØ	1	
C - 35	Dust Cover	AC6ØKPEZVØ7	1	
C - 36	Hose	AC84PJPZVØ6	1	
C - 37	Plastic Cover (Motor)	AC93FTEZØU	1	
C - 38	Wire Tie	AMC596-7Ø2	1	Shipped 10 per package
C - 39	Protector	AC69KJMZVØ6	1	
C - 40	Protector Spring - Blue	AC7ØKAHHZBØ	1	
C - 41	Protector Supporter	AC18MJMZVØ6	1	
C - 42	Protector Case	AC68KJMZVØ6	1	
C - 43	Rubber Protector	AC51E4GZUØ1	1	
C - 44	Flat Washer, Round	AXWE1ØJ223FE	1	
C - 45	Cord Retainer	ACØ6WAPNZØØ	1	
C - 46	Packing (Insulator)	AC61LAGMZØØ	1	
C - 47	Hose Hook	AC53RJPZVØ7	1	
C - 48	Wand Holder	AC7ØPJPZVØ7	1	
C - 49	Crevice Tool	AC6ØRZFZVU6	1	
C - 50	Dusting Brush	AC88RYUZVØ6	1	
C - 51	Extension Wand	AC4ØPJPZVØ6	1	
C - 52	Hose Holder	AC23PJP1VØ7	1	Includes Hose Adapter
C - 53	Screw (Wand Holder)	AXTN4+16BFY	3	Shipped 10 per package

■ EXPLODED VIEW (MOTOR FAN ASSEMBLY)

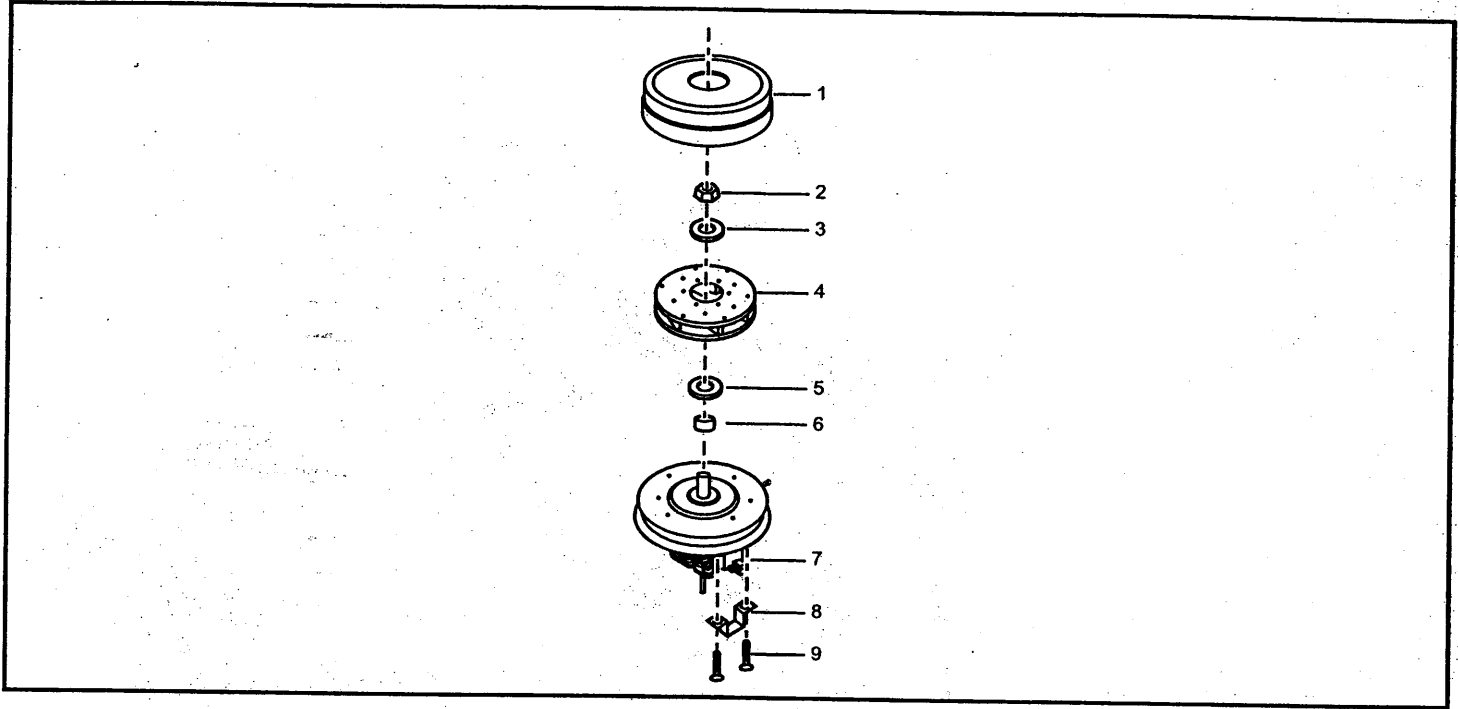

■ PARTS LIST (MOTOR FAN ASSEMBLY)

Ref. No.	Part Name & Description	Part No.	Quantity	Remarks
1	Fan Case	AMC53F-AV000U	1	
2	Nut	AMC33F-AC000U	1	
3	Washer (a)	AMC62F-AV000U	1	
4	Fan	AC98FRFZ00	1	
5	Washer (b)	AC62FRFZ00	1	
6	Spacer	AC60FRFZ00	1	
7	Brush Assembly	AC27FRFZ00	1(Set)	
8	Bracket	AMC02D-V3000U	2	
9	Screws	AMC40D-V3000U	4	

EXPLODED VIEW (PACKING MATERIALS)

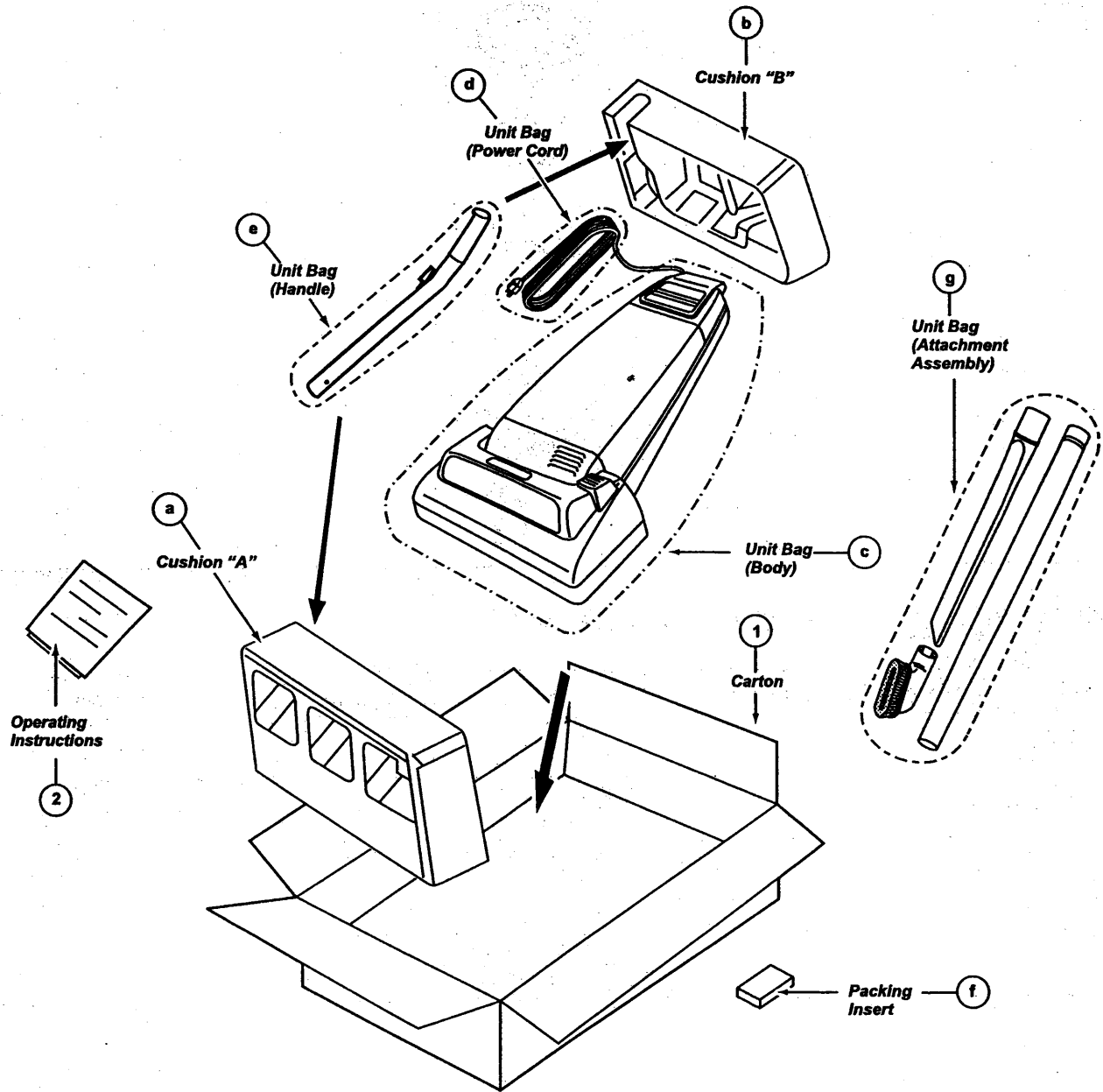

PARTS LIST (PACKAGING MATERIALS)

Ref. No.	Part Name & Description	Part No.	Quantity	Remarks
1	Packaging Assembly	AC61ZCCBZ000	1	Includes 1 and items a-g
2	Operating Instructions	AC01ZCCCZ000	1	

■ COMPONENT REMOVAL CHART

COMPONENT TO BE REMOVED	COMPONENTS THAT MUST BE REMOVED	HOW TO REMOVE
Belt	Lower Plate Agitator Assembly	Release latches, and tilt off. Lift out with end caps.
Agitator Assembly	Lower Plate Belt	Release latches, and tilt off. Lift out with agitator.
Motor	Dust Cover Lower Plate Agitator Assembly/Belt Nozzle Housing Motor Case	Pull off. Release latches, and tilt off. Lift out with end caps. Pull off. Remove four screws and pull off.
On-Off Switch/ Power Cord	Dust Cover Switch Cover	Pull off. Remove two screws and pull off.
Nozzle Housing	Lower Plate Agitator Assembly/Belt Height Adjust Assembly	Release latches, and tilt off. Lift out with end caps. Remove three (3)screws and lift out.
Motor Protector	Dust Cover Dust Bag	Pull off. Pull out of dust compartment

■ LOWER PLATE REMOVAL/INSTALLATION

Removal

1. Place the handle in upright position.
2. Turn the vacuum cleaner over exposing the underside. Release the lower plate by pressing the two (2) latches that secure it inward, (Fig 1).
3. Separate the lower plate from the vacuum.

Installation

1. Hook the front of the lower plate into the slots on the front of the nozzle housing. Press the lower plate down into place.
2. Fasten the lower plate by pushing the two (2) latches outward.

NOTE: For general servicing, it is necessary to eliminate pinching of any wire during reassembly. After servicing any electrical component or electrical enclosure, the unit should be reassembled and checked for dielectric breakdown or current leakage.

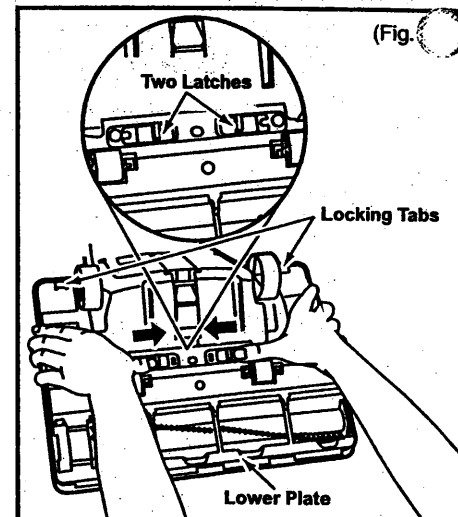

■ AGITATOR ASSEMBLY REMOVAL/INSTALLATION

Removal

The brushes are replaceable separately. When the brushes need replacing, the agitator assembly will have to be removed.

1. Remove the lower plate as outlined in the LOWER PLATE REMOVAL/INSTALLATION section.
2. Carefully lift up on the agitator assembly until it clears both sides of the nozzle housing, (Fig. 2).
3. Remove the belt from the motor shaft by sliding it off between the end of the shaft and the nozzle housing, (Fig. 3).

NOTE: The two (2) end caps may come off as you lift the agitator assembly out. Look at the exploded view of the agitator assembly in the B Block section for correct assembly of parts. The end caps can be reused.

Installation

1. Place the belt around the motor shaft, (Fig. 3).
2. Start the new agitator assembly back into the nozzle housing by placing the side opposite the belt partially into the slot. This will hold the agitator in place, and leave both hands free to place enough tension on the belt to allow that side of the agitator to return to the nozzle housing slot.
3. Place the belt around the agitator pulley on the agitator assembly.

Note: There is a place for the belt to fit on one end of the agitator assembly only. This is the agitator pulley.

4. Use both hands to pull the belt tight, (Fig. 4), and slide the agitator assembly firmly into the slots on each end of the nozzle housing.
5. Rotate the agitator assembly by hand to insure nothing rubs and to check for correct assembly.
6. Replace the lower plate as outlined in the LOWER PLATE REMOVAL/INSTALLATION section.

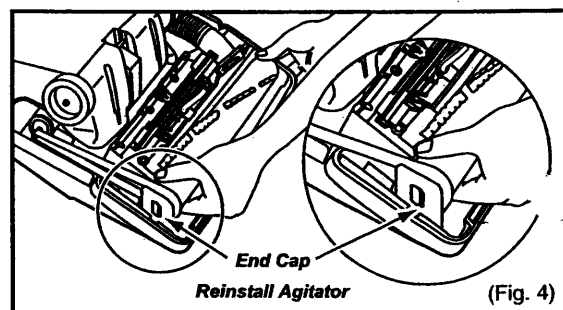
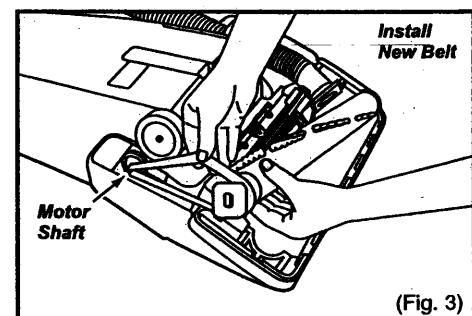
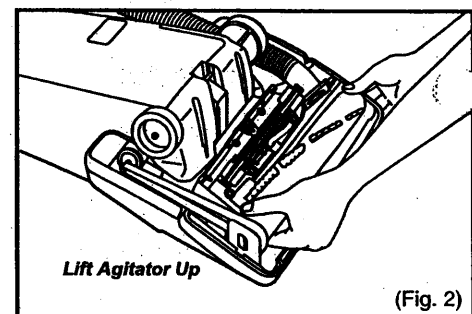

■ BRUSH REMOVAL/INSTALLATION

Removal

1. Remove the lower plate as outlined in the LOWER PLATE REMOVAL/INSTALLATION section.
2. Remove the agitator assembly as outlined in the AGITATOR ASSEMBLY REMOVAL/INSTALLATION section.
3. Note the position of the brush and beater bar. Push worn brushes out of agitator assembly, (Fig. 5).

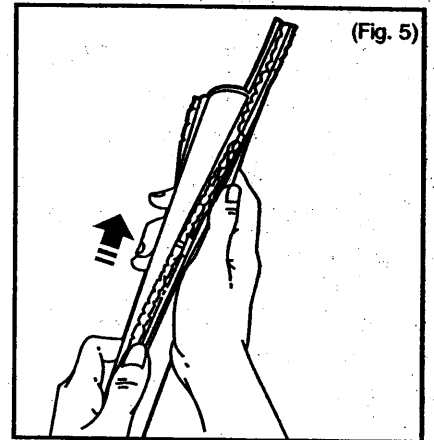

Installation

1. Slide new brushes into slot, making sure not to reverse the brush and beater bar position.

Note: New brushes may be easier to install if they are soaked in warm water for a few minutes and then dried completely prior to installation.

2. Replace the agitator assembly as outlined in the AGITATOR ASSEMBLY REMOVAL/INSTALLATION section.
3. Replace the lower plate as outlined in the LOWER PLATE REMOVAL/INSTALLATION section.

■ BELT REPLACEMENT

Removal

1. Follow all of the instructions outlined in the agitator assembly removal section.

Installation

1. Place the new belt around the motor shaft and follow the instructions in the agitator assembly replacement section.

■ NOZZLE HOUSING REPLACEMENT

Removal

1. Remove the lower plate as outlined in the LOWER PLATE REMOVAL/INSTALLATION section.
2. Remove the belt and agitator assembly as outlined in the respective sections.
3. Remove the nozzle hose by pulling up to remove it from the nozzle housing. Pull the nozzle hose out of the back of the nozzle housing.
4. Insert a flat blade screwdriver between the nozzle housing and the plastic shaft, pry out the plastic shaft as illustrated, (Fig. 6).
5. Remove the nozzle housing as illustrated, (Fig 7).
6. Remove the window and height adjust assembly.

NOTE: If the motor case is removed, DO NOT turn vacuum over as the motor may fall out.

Installation

1. Install the window and height adjust assembly in the new nozzle.
2. Fit the nozzle from the motor shaft side first, and rotate it into place on the dust container as illustrated, (Fig. 8).
3. Slide the plastic shaft through the nozzle housing and into the dust container. Make sure that the slot on the bottom of the plastic shaft is down and fitted onto the projection, (Fig. 9).
4. Reassemble the nozzle hose by inserting it into the nozzle. Push the nozzle hose down into the slot in the nozzle housing.
5. Install the belt, agitator assembly, and the lower plate according to the respective instructions.

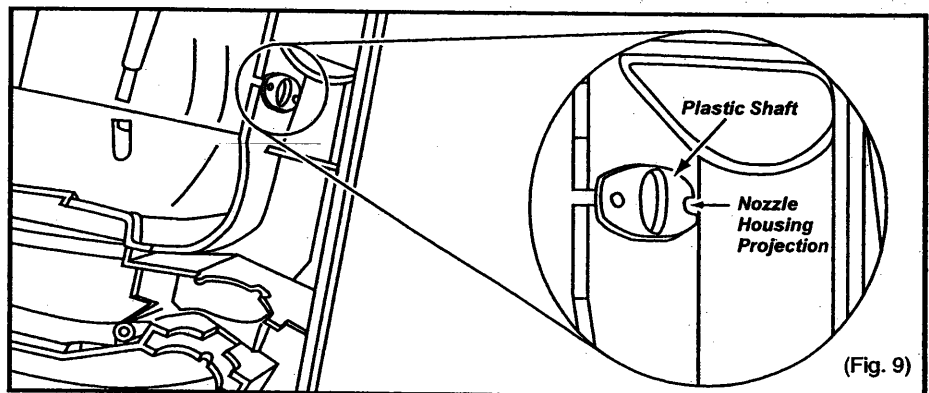
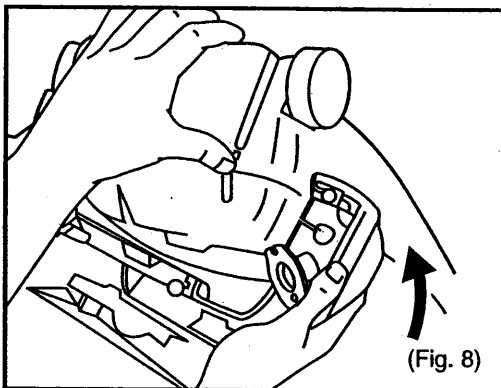
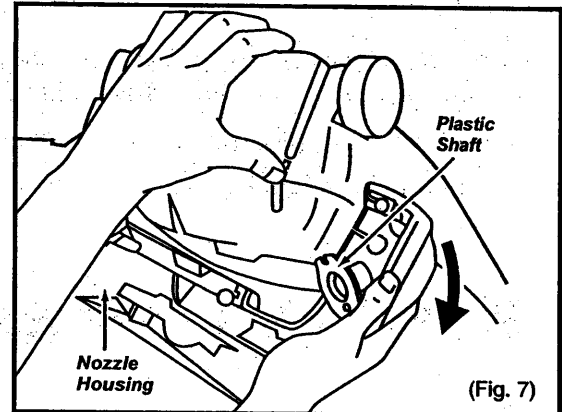
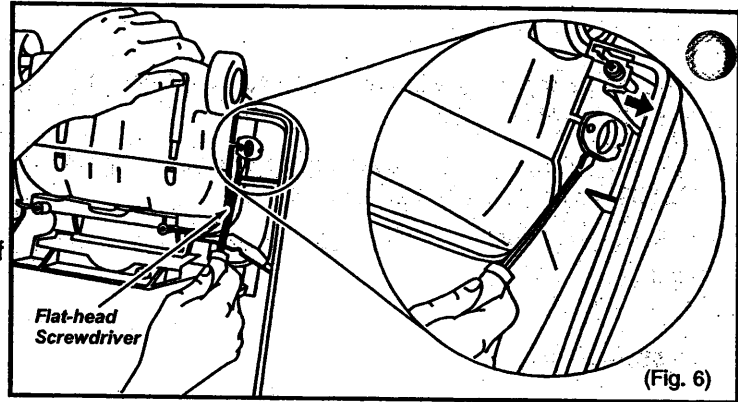

■ SWITCH COVER AREA WIRING MANAGEMENT

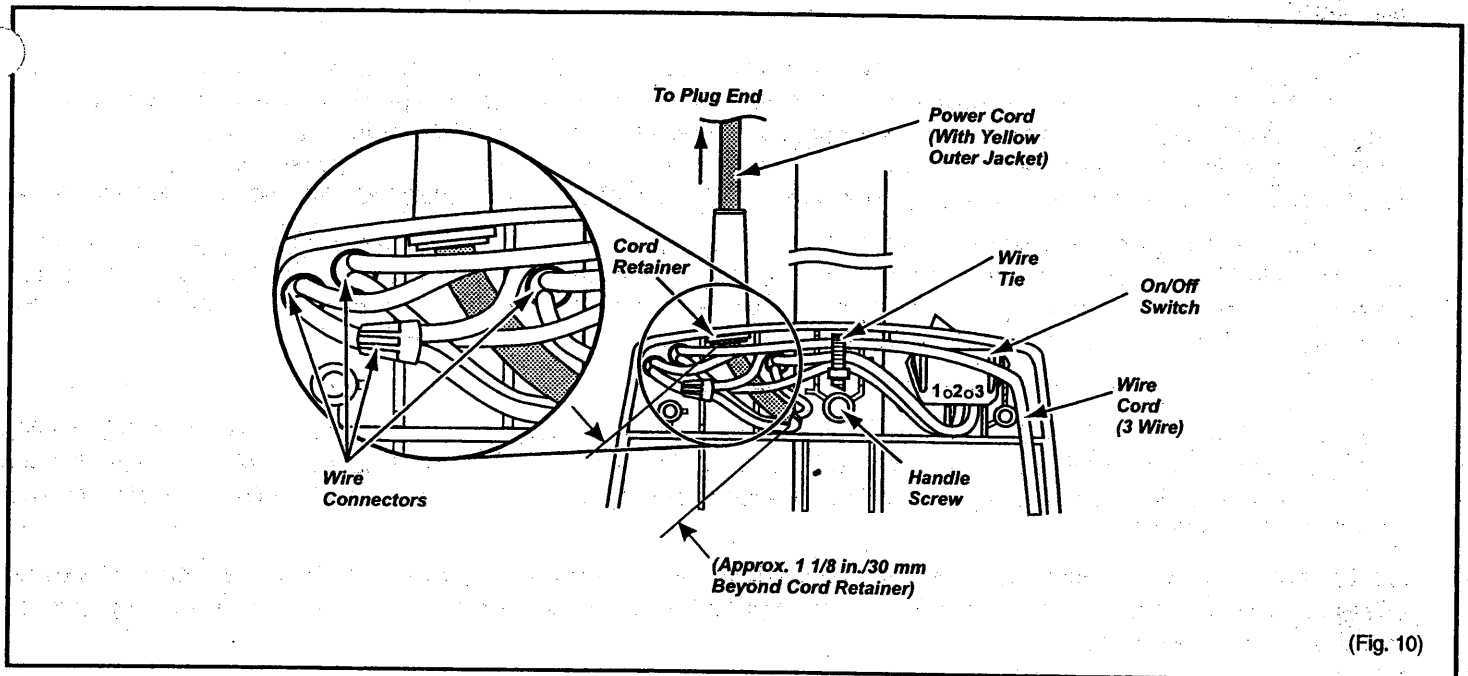

■ POWER CORD/ON-OFF SWITCH REPLACEMENT

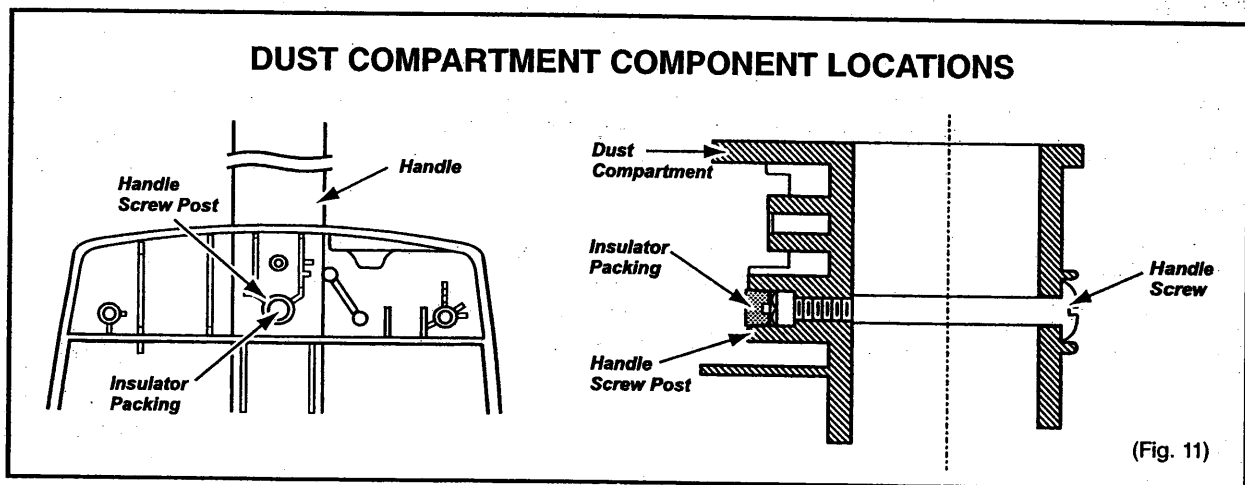

Removal

1. Remove the dust cover and switch cover to expose the electrical connections of the power cord, ON/OFF switch, and wire cord.
2. Pull the power cord into the dust compartment in order to remove the strain relief (for power cord replacement) by prying or cutting, remove the wire connectors, and wire tie, if present.
3. Remove the ON/OFF switch (for ON/OFF switch replacement) by depressing the switch retaining tabs while pushing up out of the dust compartment at the same time.
4. Pull the power cord out of the dust compartment (for power cord replacement).

(Continued on p. 16)

■ POWER CORD/ON-OFF SWITCH REPLACEMENT (Cont.)

Installation

1. Insert the new power cord (power cord replacement only) into the dust compartment as far as necessary in order to place a new cord retainer in proper location on power cord. The proper location is approximately one and one eighth inches/thirty millimeters (1 1/8"/30 mm) of new power cord outer jacket extending past the cord retainer and washer. The washer goes between the cord retainer and the dust compartment. Attach wires with wire connectors according to the wiring diagram in the front of this manual. **ONLY USE A NEW CORD RETAINER, DO NOT REUSE A CORD RETAINER.**
2. For switch replacement only, insert the new ON/OFF switch with the numbers 1,2,3, facing toward you, into the dust compartment until secured by the retaining tabs. Use a wire tie with the part number listed in the **C Block** parts list and place it in the location shown in *Fig. 10* taking care not to overtighten it. Tuck the wire connectors back into the dust compartment as shown in the close-up view in *Fig. 10*.
3. Ensure that the Insulator Packing is installed correctly, (see *Fig. 11*).
4. Replace the switch cover, the two (2) switch cover screws, and the dust cover. Care should be taken not to pinch wires and make sure that the switch cover goes on easily and stays flat. If there is resistance to the switch cover lying flat and in place, stop, remove the cover and make sure that no wires are being pinched. **DO NOT USE A POWER SCREWDRIVER TO SECURE THE COVER.**

NOTE: Any service involving the handle or switch cover area should be followed up with a dielectric or current leakage check of the unit. If you do not have the equipment or are not familiar with the test procedures, take the unit to an authorized servicer.

■ MOTOR PROTECTOR REPLACEMENT

Removal

1. Remove the dust cover and dust bag.
2. Remove the motor protector (shown in the **C Block**) by pushing in, one at a time, on the tabs that secure it to the dust compartment. Push the motor protector out the back of the dust compartment.

Disassembly

1. Holding a pair of needle nose pliers at an angle and in a position where one side of the pliers is against the locking tab, exert enough pressure on the tab to release it, (see *Fig. 12*). **NOTE: There are two locking tabs present, but only one needs to be released. For reassembly look at the exploded view in the C Block.**

Installation

1. Reinstall the motor protector into the dust compartment by aligning the two tabs under the top flange with the slots in the dust compartment and applying pressure until it snaps into place.

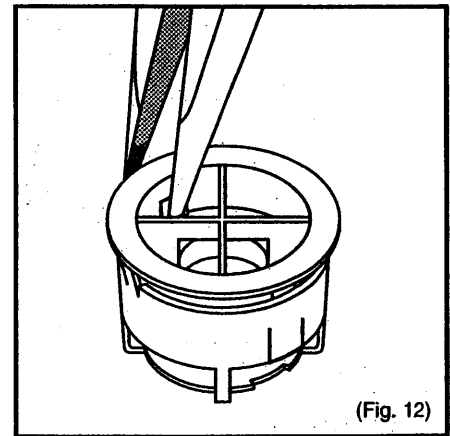

MOTOR REPLACEMENT

Removal

1. Remove the dust cover by grasping the top near the On/Off switch and pulling sharply out toward you.
2. Remove the lower plate, agitator assembly, belt, and the nozzle housing as instructed in the respective removal sections.
3. Turn the vacuum over to the front side.
4. Remove the four (4) screws from the motor case and then remove the motor case, (Fig. 13).
5. Disconnect the motor leads and remove the motor. Remove the motor support rubber (rear), noise suppressor, and the motor support rubber (front). Place these items on the new motor. See the **C Block** for a view of these.

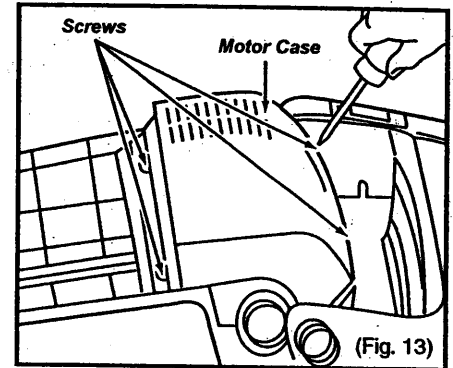

Installation

1. Place the motor back into the dust compartment with brushes aligned parallel to the front edge of the dust compartment. The motor support (rear) must also align with the tabs in the same direction.
2. Rewire per the **Pictorial Wiring Diagram**.
3. Replace the motor case and the four (4) screws.
4. Turn the vacuum back over and replace the nozzle housing, belt, agitator assembly, and lower plate according to the respective installation instructions.

CARBON BRUSH REPLACEMENT

Removal and Installation

1. After removing the motor, see MOTOR REPLACEMENT, make sure that you have properly identified it. Note specifically that this motor is made in the U.S.A. as identified by the label on the side of the motor, or Made in U.S.A. stamped on the bottom.
2. Remove the amp terminals located on each brush end, (Fig. 14). Replace the brush assembly which should include the brush holder. Reinstall the amp terminals onto the new brush assembly. Complete brush change on one side before starting on the other side.

NOTE: Do not drop screws into the motor.

3. There are two (2) brushes located on the motor as identified in Fig. 13. A Phillips head screwdriver will be required to remove the four (4) screws that hold the brush holders onto the motor. See Fig. 14 for screw location.

NOTE: When inserting the brush assembly, be sure that the TAB on the bottom of the brush holder is positioned in the trough as shown in Fig. 15.

4. Replace the brush holder bracket with two (2) Phillips screws on each side of the motor.
5. As a final check to assure proper installation of brushes, measure across the brushes for the approximate dimension as shown in Fig. 15.

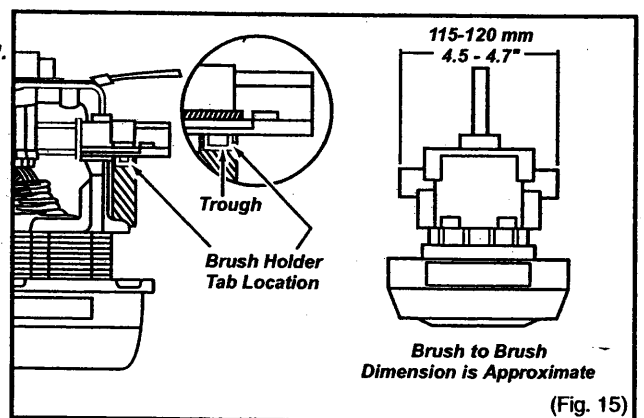
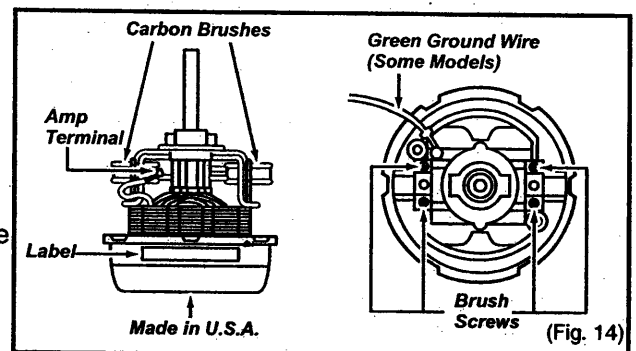

■ TROUBLESHOOTING GUIDE

CONDITION	CHECKPOINT	METHOD OF INSPECTION	CAUSE/REMEDY
MOTOR FAILS TO ROTATE, (NO NOISE IS HEARD AT ALL).	<ul style="list-style-type: none"> • Power source (plug socket). • Power cord. • Motor continuity. • Motor carbon brush is in contact with rotor. • ON/OFF switch continuity. 	<ul style="list-style-type: none"> • Measure power source voltage at plug socket by use of tester. • Remove AC plug from the AC wall outlet. Connect ohm-meter across both ends of the power cord plug and operate the ON/OFF switch. If the meter indicates continuity, the AC cord, switch, motor winding are OK. • If no continuity is found, proceed as follows: Remove dust cover and the switch cover, short across AC plug ends, open the ON/OFF switch and read across the black and white leads of the AC cord. If continuity, cord is OK. If no continuity, AC cord is open. • Check continuity of motor. • Remove noise suppressor and check if there is gap between carbon brushes and rotor. • Remove switch cover, and check continuity across switch terminals. 	<ul style="list-style-type: none"> • Power source is fault if voltage is lower than specified. • Replace AC cord. • If there is no continuity of motor replace motor. • If there is gap between carbon brush and rotor, cause is either dust accumulated in brush holder or carbon brush worn out. Adjust or replace. • If there is no continuity between both terminals, ON/OFF switch must be defective.
SUCTION POWER IS TOO WEAK.	<ul style="list-style-type: none"> • Dust bag. • Filters. • Nozzle hose. 	<ul style="list-style-type: none"> • Check quantity of dust accumulated in dust bag. • Check for dirty filter. • Remove nozzle hose and check. 	<ul style="list-style-type: none"> • Replace dust bag if full. (Paper) Empty dust bag. (Cloth) • Clean and/or Change Filters. • If clogged, remove clog.
NOISE OR VIBRATION.	<ul style="list-style-type: none"> • Dust in motor fan. • Carbon brushes. • Agitator roller bearing noise. • Lower housing agitator grooves. 	<ul style="list-style-type: none"> • Check dust accumulated in motor fan. • Check uneven wear of carbon brushes. • Hold bearing units in hand, and turn agitator, check rolling noise the agitator pulley section makes. • Agitator should turn freely without any drag or friction. 	<ul style="list-style-type: none"> • Clean dust out of motor fan and check filter condition. • Replace carbon brushes. (Be sure to replace both carbon brushes at same time.) • If noise is abnormal, agitator end cap is defective. Replace defective end cap. • Lower housing is worn.
AGITATOR DOES NOT ROTATE.	<ul style="list-style-type: none"> • Belt. 	<ul style="list-style-type: none"> • Check condition of belt. 	<ul style="list-style-type: none"> • Replace belt if necessary.

MOTOR FAN REPLACEMENT

Removal

1. Mark the position of the fan case's location on the motor with a pencil, or score it with a sharp object before disassembly. This will aid you in reassembling the fan case, (Fig. 16).
2. The fan case has three (3) crimped sections on it to hold the case onto the motor. These will have to be straightened by using a pair of needle nose pliers and by tapping out on the crimp area with a flat blade screwdriver. Be sure and straighten all three (3) crimped areas, (Fig. 16). Remove the fan case from the motor unit.
3. Tools required to remove the fan from the shaft will be a 1/8 - inch Allen wrench, a 1/2 -inch offset box wrench, torque wrench, and a hammer.

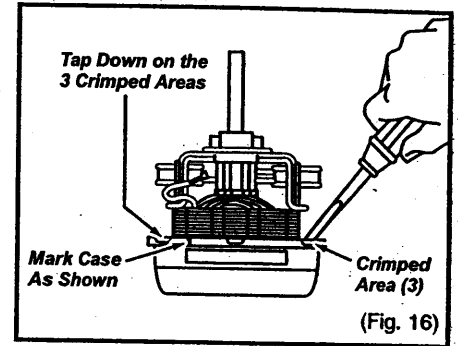

NOTE: Be careful when handling the sheet metal parts as there could be sharp edges. Do not scratch or bend the motor shaft. Scratches will cause belt breakage during operation.

4. Place the 1/2 - inch box wrench over the 1/2 -inch hex nut that holds the fan onto the motor shaft, (Fig. 17). While holding the wrench on the nut, place the 1/8 -inch Allen wrench into the end of the motor shaft and loosen the nut while holding the Allen wrench still. The nut will have to be turned clockwise as it is a left-hand thread. After removing the nut, remove the fan, (Fig. 17). There is a spacer left on the motor that is not required to be removed. If spacer is removed, reassemble per exploded view, (Fig. 19).

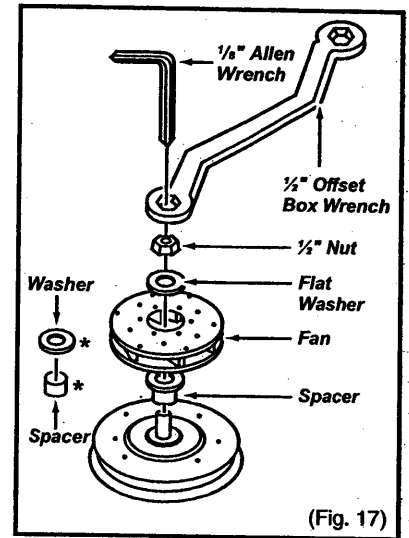

* Some models will have this washer and spacer.

Installation

1. Place the new fan onto the motor shaft, making sure that the spacer is still on the motor. The large diameter hole, approximately 1 1/8 inch, will be on the top of the fan as you install it.
2. Install the flat washer with the burr side of the washer facing away from the fan, (Fig. 19). Screw the nut onto the motor shaft, turning it counterclockwise, left-hand threads, and torque to 20-30-inch pounds. Be sure to hold the motor shaft by placing the 1/8-inch allen wrench into the motor shaft end while torquing the nut, (Fig. 17).
3. Align your marks on the fan case as you put the fan case back on and tap around the case uniformly. Tap the three (3) crimped areas over and then use a flat blade screwdriver to recrimp them.
4. See Fig. 18 for reassembly specifications.

EXPLODED VIEW

