

# DUST 2000

**ORDER #85016**

## *2000 RPM Dust Control Burnisher*

### FEATURES

- Quick Detachable Handle for Easy Transport
- Patented Infinite Position Handle Height Adjustment
- Super-Flex Switch Levers
- Safety Switch Lock-Out
- Cleanable Dust Control Filter
- Adjustable Dial for Precise Pad Pressure
- Heavy Duty Transport Wheels
- Flexible High Speed Pad Driver
- Direct Drive - No Belts, Gear Box or Pulleys
- Heavy Duty Motor for Durability and Long Life
- 75' Safety Yellow Power Cord 14/3 Ga.

The Betco Dust Control series of high speed burnishers are engineered for easy use, operator safety, and system performance. The high RPM's allow this machine to compliment any high speed floor maintenance program. The Dust Control feature makes this unit particularly effective in healthcare facilities. All Betco Burnishers are CSA safety tested and certified. Built with the highest quality components, Betco Burnishers provide outstanding performance and durability.

### WARRANTY

3 year (except wear items)\*  
10 year unconditional rotationally molded base.

\*Please refer to Betco Equipment Price/Product Guide for complete equipment warranty information.

**Authorized Betco Distributor:**



### SPECIFICATIONS

- Pad Size: 19"
- Pad Speed: 2000 RPM
- Motor: 1.5 hp DC Rectified
- Amp Draw: 14.5 amps
- Cord: 75' Safety Yellow 14/3 Ga.
- Plug: Hospital Approved 3 prong
- Noise Level: 58 dB
- Weight: 76 lbs. (Net)
- CSA Tested and Certified

### APPLICATIONS

- Dry Burnishing
- Restorative Burnishing

**Better Resources. Better Results.**  
**BETCO**®

1001 Brown Avenue • P.O. Box 3127 • Toledo, Ohio 43607-0127  
©All Rights Reserved 12/00 • Reorder #85016 • email@betco.com • www.betco.com

# DUST2000 20" Dust Control Burnisher

## Parts Schematic

Order #85016

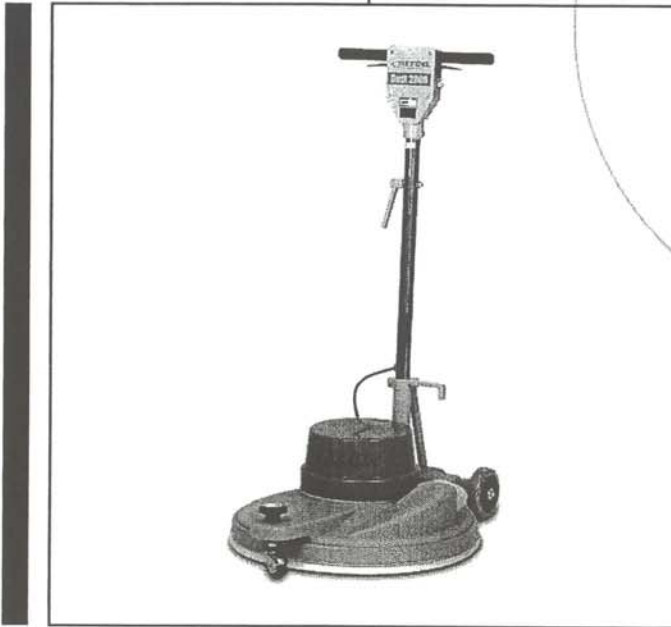

*Better Resources. Better Results.*  
**BETCO**<sup>®</sup>

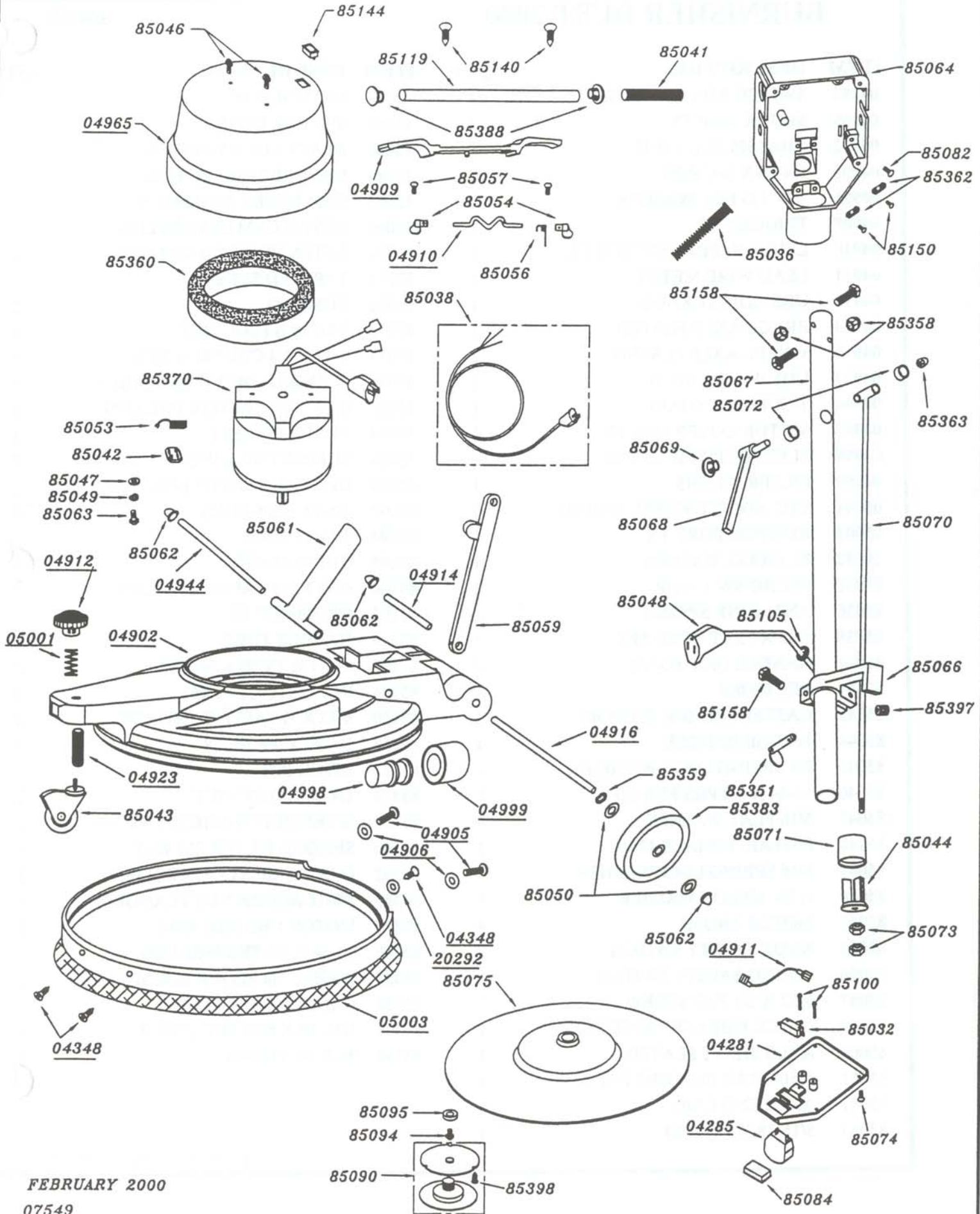

# BURNISHER DUST 2000

85016R

ITEM	DESCRIPTION	QTY	ITEM	DESCRIPTION	QTY
04281	SWITCH BOX COVER TX	1	85064	SWITCH BOX	1
04285	METER AMP TX	1	85065	SW/ BOX COVER	1
04902	CHASSIS-POLY UHS	1	85066	BRACE LOCK PAINTED	1
04905	1/4-20 X 3/4" PHS	2	85067	HANDLE TUBE PLATED	1
04906	1/4" LG DIA. WASHER	2	85068	CAM LEVER ASSEMBLY	1
04909	TRIGGER TX	1	85069	HEYCO CAM LEVER PLUG	1
04910	LEVER SAFETY SWITCH TX	1	85070	EXTENSION ROD WELDED	1
04911	LEAD WIRE-METER	1	85071	TAPERED SLEEVE	1
04912	UHS ADJUST KNOB	1	85072	BUSHING	2
04914	BRACE AXLE PLATED	1	85073	5/16-18 NYLOC NUT	2
04916	WHEEL AXLE PLATED	1	85074	8-32 X 1/4 C'SUNK SCREW	4
04923	UHS WHEEL STUD	1	85075	FLEXIBLE DRIVE ASSEMBLY	1
04944	T-SUPPORT SHAFT	1	85082	8-32 X 1/4 TAPTITE PHILLIPS	1
04965	MOTOR COVER UHS TX	1	85084	SWITCH INSERT	1
04998	SLEEVE FILTER TX UHS	1	85089	SUPPORT BRACKET	4
04999	FILTER TX UHS	1	85090	UHS PAD CENTRE LOK	1
05001	UHS ADJUST WHEEL SPRING	1	85092	3/8-16 X 5/8 HHCS	4
05003	BUMPER/SKIRT TX	1	85094	5/16-18 SHCS	1
20292	8L BRASS WASHER	1	85095	CUP WASHER	1
85032	MICRO SW 1 1/2 HP	1	85100	6-32 X 7/8 TAPTITE PHILIPS	2
85036	ANTI-KINK SPRING	1	85105	GROMMET 3/8"	1
85038	14/3 X 75 FT CORD SET	1	85119	HANDLE TUBE	1
85041	HANDLE GRIP FOAM	2	85140	#14-1 1/2 TYPE A SCREW	2
85042	RECTIFIER	1	85144	INDICATOR LIGHT	1
85043	CASTER UHS B/R SUPPORT	1	85150	8-32 X 1/2 TAPTITE PHILLIPS	4
85044	WEDGE HANDLE	1	85158	1/4-20 X 3/4 HHCS	3
85045	3/8 SPRING LOCK WASHER	4	85351	HITCH PIN	1
85046	10-24 X 1/2 PHS PHILLIPS	2	85358	1/4-20 NYLOC NUT	2
85047	5/16 FLAT WASHER	4	85359	1/2 TENSION WASHER TW8	2
85048	PIGTAIL FEMALE 42 IN.	1	85360	SHROUD FILTER SM WET	1
85049	5/16 SPRING LOCKWASHER	4	85362	CORD GRIP-STRAIN RELIEF	2
85050	1/2 IN. NYLON WASHER	4	85363	3/8-16 ACORN NUT FLANGED	1
85053	MOTOR BRUSH	4	85370	MOTOR UHS 2000 RPM	1
85054	KNOB SAFETY SWITCH	2	85380	10-24 X 3/4 PHS PHILLIPS	1
85056	SPRING SAFETY SWITCH	1	85383	WHEEL 5in FLOOR MACH	2
85057	6-32 X 1/4 TAP SCREW	2	85388	HANDLE TUBE PLUG	2
85059	HANDLE BRACE PAINTED	1	85397	5/16-18 X 5/16 SET SCREW	1
85060	AXLE SHAFT PLATED	1	85398	#8 X 5/8 PHSMS	6
85061	T-HANDLE SUPPORT PAINT	1			
85062	AXLE END CAPS	6			
85063	5/16-18 X 1 1/2 HBB	4			

# Betco Equipment Division

## OPERATION OF UHS POLISHERS WITH AMP METER ATTACHED

The AMP meter is designed to assist the operator in setting polisher pad pressure on the floor. This will assure the operator that the optimum pad contact pressure setting is attained without causing an excessive current draw due to overloading the motor.

**Note:** This polisher should only be used by a trained operator. Please follow all safety procedures.

1. Set your UHS unit on a clean, dry, flat floor and adjust the handle to the operating position suitable for you. Plug the unit into a 120 Volt supply wall receptacle.
2. Adjust the front wheel support by turning the adjusting knob clockwise to the end of the thread travel. This will lift the unit to its highest position.
3. From the operators position (with both hands on the handle bars) start the polisher. The meter indicator needle should be in the green zone far from the red zone.
4. Allow the machine to stop and adjust the front wheel support by turning the knob approximately two or more turns counter-clockwise. This will lower the unit increasing pad contact pressure with the floor.
5. Start the machine, as in #3, and observe the meter. The needle should be closer to the red zone. The polisher is operational at this point but some operators may want to lower the pad more. Repeat knob adjustments until desired setting is reached but **DO NOT LET THE MACHINE OPERATE CONTINUOUSLY IN THE RED ZONE!** This means that the motor is drawing excessive current and a breaker or fuse on the power supply circuit may blow.

**Note:** Due to different floor and operating conditions, the indicator needle may jump into the red zone temporarily and return to green. To avoid this, adjust the pad pressure by turning the support knob clockwise until the needle stays in the green zone.

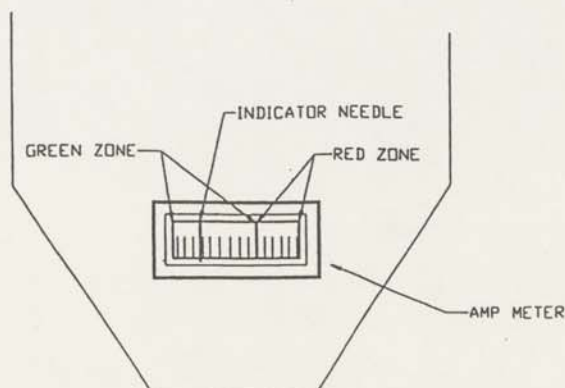

May 98

*FRONT OF SWITCH BOX*

# DUST2000 20" Dust Control Burnisher

## Operator's Manual

Item #85016



Better Resources. Better Results.  
**BETCO**<sup>®</sup>

## INTRODUCTION

This manual will help you get the most from your Betco Burnisher. Read it thoroughly before operating.

The Betco Burnisher is intended for commercial use.

### **PARTS & SERVICE:**

Contact your BETCO AUTHORIZED DISTRIBUTOR for repair parts or service. Please specify the Model & Serial Number when discussing your machine.

### **NAME PLATE:**

The Model & Serial Number of your machine is located on the Name Plate on the back of the handle assembly. This information is often needed when ordering repair parts for the machine.

---

## IMPORTANT SAFETY INSTRUCTIONS

When using an electrical appliance, basic precautions should always be followed, including the following:  
Read all instructions before using.

### **! WARNING!**

To reduce risk of fire, electric shock, or injury:

- \* Do not leave the machine when it is plugged in. Unplug the unit from the outlet when not in use & before servicing.
- \* To avoid electric shock, do not expose machine to rain. Store indoors.
- \* Do not allow to be used as a toy. Close attention is necessary when used by or near children.
- \* Use only as described in this manual. Use only manufacturer's recommended attachments.
- \* Do not use with damaged cord or plug. If machine is not working as it should return it to a service center for inspection.
- \* Do not pull or carry by cord, use cord as a handle, close a door on a cord, or pull cord around sharp edges or corners. Do not run machine over cord. Keep cord away from heated surfaces.

- \* Do not unplug by pulling on cord. To unplug, grasp the plug, not the cord.
- \* Do not handle plug or machine with wet hands.
- \* Do not put any foreign object into openings. Do not use with any opening blocked; keep free of dust, lint, hair, & anything that may reduce airflow.
- \* Keep hair, loose clothing, fingers, & all parts of body away from openings & moving parts.
- \* Turn off all controls before unplugging.
- \* Do not use in or around flammable or combustible liquids such as gasoline or use in areas where they may be present.
- \* Connect to a properly grounded outlet only. See grounding instructions.

---

#### GROUNDING INSTRUCTIONS

This machine must be grounded. If it should electrically malfunction, grounding provides a path of least resistance for electric current to reduce the risk of electric shock. This machine is equipped with a cord having an equipment-grounding conductor & grounding plug. The plug must be plugged into an appropriate outlet that is properly installed & grounded in accordance with all local codes & ordinances.

**! DANGER!**

Improper connection of the equipment-grounding conductor can result in a risk of electric shock. Check with a qualified electrician or service person if you are in doubt as to whether the outlet is properly grounded. Do not modify the plug provided with the machine. If plug will not fit the outlet, have a proper outlet installed by a qualified electrician.

Replace the plug if the grounding pin is damaged or broken.

Extension cords connected to this machine should be 12 gauge, 3-wire cords with 3-prong plugs & outlets. DO NOT use extension cords more than 50 feet long.



---

## PREPARING THE MACHINE FOR OPERATION

### **! WARNING!**

This machine contains moving parts. To reduce the risk of injury, always unplug the power cord before servicing.

With the handle locked in the upright position, tip the entire machine backward, resting on handle assembly.

Align the proper burnishing pad on the flex-drive pad drive assembly, secure with locking plate, hand tight only.

### **! CAUTION!**

Using the wrong pad on this machine can damage the floor or overload the motor.

Before using, always make sure floor is clean & dry.

Unwrap the power cord completely & plug into a properly grounded outlet.

Adjust the handle to a comfortable position. This adjustment will vary from operator to operator.

Adjust the burnishing head for proper pad pressure using the adjustment knob located on the front of the burnisher.

Be prepared to control the machine as soon as you release the safety lock tab & pull either switch lever.

Immediately start moving forward. Keep the machine moving while the motor is running.

Note: When the dual controlled switch levers are released, the machine shuts off immediately.

---

## PROCEDURE'S

### RESTORER BURNISHING Dust 2000 Dust 2500

Lightly mop floor with properly diluted restorer. Allow to dry before burnishing.

Each side of a burnishing pad will cover approximately 500 square feet. Floors will require scrubbing & recoating periodically depending on wear & use.

Note: Dust Control Models Should Not Be Used For Spray Buffing. Spray Buffing Will Clog Filter And Damage Dust Control Skirt.

---

## AFTER USE

Return handle assembly to the upright, locked position.

Unplug the power cord, starting from the machine wrap the power cord onto the handle assembly.

With the machine in the upright, locked position, tip the entire machine backward, resting on the handle assembly.

Remove the burnishing pad from the machine. (Clean all burnishing pads)

Wipe the entire machine with a clean, damp cloth.

Inspect the machine & all accessories for damage. Perform any required maintenance or repairs before storage.

Store the machine in a clean, dry place with the handle in the upright, locked position resting on pad.