



E83018-00



# CREWMAN™ DC2000

20" Dust Control  
Electric Burnisher



**Operator and Parts  
Manual**

# General Instructions for the CREWMAN™ DC2000

## Operating Instructions

Check machine for damage to cord or plug.

Use only Hi Speed Burnishing pads 20" or 19" diameter.

To install or change the pad:

1. Unplug the machine.
2. Tip the machine back on the wheels.
3. Remove the center-lock.
4. Center the pad on the pad driver.
5. Replace the center-lock and tighten securely.

To operate the machine:

1. Plug into a grounded outlet.
2. Release the handle and lower it.
3. The handle can be locked into a comfortable position for the operator or used free floating.
4. Press the safety lever and squeeze the trigger to start the machine.
5. Do not operate in one place as damage to the floor or finish could result.
6. The machine should be operated in the green area of the meter on the handle. Turn the knob on the back to increase or decrease the pad pressure.
7. Do not operate the machine with the handle in the upright position.
8. Remove the pad after every use.
9. Use only new or clean pads and reverse them as needed.

## Specifications:

Length - 30 in.

Width - 22 in.

Height - 50 in.

Weight - 69 Lbs.

Pad Speed - 2000 RPM

Pad Diameter - 20 in.

Drive motor - 1.5 HP, 120v, 15 A, 50/60 HZ

Cord - 14-3 ST, 75 ft.

## Safety

Read and understand the manual before operating this machine.

- Do not operate in explosive areas or use near flammable liquids or gases.
- Attach only to properly grounded outlet.
- Do not expose to rain, store indoors.
- Do not operate the machine with a damaged cord or plug.
- Do not block or disconnect the safety lever.
- Do not leave the machine plugged in while unattended.
- Unplug the machine before servicing.
- Do not put fingers under the pad or pad holder.
- Unplug the machine before installing or removing the pad.
- Use only with Hi Speed Burnishing pads.

## Maintenance

To maintain appearance - wipe the machine with a damp cloth after use.

*Warning* - Unplug the machine before servicing

The operator should check the following at 250 hour intervals:

1. Check the motor brushes for wear or excessive arcing.
2. Check the cord and electrical system.
3. Check the safety lockout on the trigger.
4. Check wheels and bearings.
5. Check the Dust shroud and brush seal.
6. Check the Dust bag before each use.

### BETCO US WARRANTY POLICY

#### 10 Year Coverage

Subject to the conditions stated below, Betco warrants parts and labor on rotationally molded polyethylene tanks/housings and injection molded vacuum head assemblies to be free from defects in materials and workmanship for a period of ten years to the original purchaser.

#### 3 Year Coverage

Subject to the conditions stated below, Betco warrants parts and labor on all other Betco components to be free from defects in materials and workmanship for a period of three years to the original purchaser.

#### 1 Year Coverage

Subject to the conditions stated below, Betco offers a limited warranty on parts and labor on the following equipment: parts and accessories to be free from defects in materials and workmanship for a period of one year to the original purchaser. DM Series Vacuums: #85506-00, #85507-00 Bac Pac Lite Vacuum: #85903-00 FiberPRO® Floor Dryer: #85507-00 WORKMAN™ Series Vacuums: #85024-00, #85025-00, #85026-00, #85027-00 CV100T Vacuum: #85023-00. All Tools and Accessories/All Battery Chargers/All Batteries are pro-rated for 1 year.

#### Allowable Travel Time Warranty Reimbursement:

Eligible equipment: All battery and propane powered equipment products. Warranty period: 90 days from date of sale to the original purchaser. A maximum 180 mile round trip at 50 cents per mile will be allowed for warranty consideration.

#### Propane Machine Warranty:

Kawasaki engines are warranted by Kawasaki for a period of 2 years against manufacturer defects. All other components (except wear items)\* are warranted by Betco for a period of 3 years.

**\*Wear Items exempt from Warranty consideration include but may not be limited to: power cords, transport wheels, vacuum bags, belts, squeegee blades, pad drivers, clutch plates, handle grips, filters, screens, throttle cables, brushes and carbon brushes.**

Subject to the conditions and exceptions stated in this warranty, Betco warrants the Betco products to be free from defects in material and workmanship, under normal use and service, for the periods listed under the warranty policy to the original purchaser. At any time during the warranty period, Betco will furnish replacement parts for the Betco parts to the original purchaser. Such parts will be furnished and charged including transportation costs, to the original owner through any Betco authorized Service Distributor. If the original part is returned within the warranty policy period from date of delivery for inspection by Betco and is found to be defective the owner will be credited for the cost of replacement parts plus shipping and handling. Replacement parts that have become defective through wear or abuse are not included in this warranty. This warranty does not apply to damage or defect caused by accident, misuse, negligence, fire, or to any Betco product which has been serviced or repaired by other than an authorized Betco Service Distributor or Betco factory personnel. This warranty is void if products are used for any purpose other than that which was intended. There are no other warranties expressed or implied. In no event shall Betco be liable for incidental or consequential damages or any damage to person or property. (Please note some states do not allow the exclusion or limitations for incidental and consequential damages).

# BURNISHER MODEL CREWMAN™ DC2000

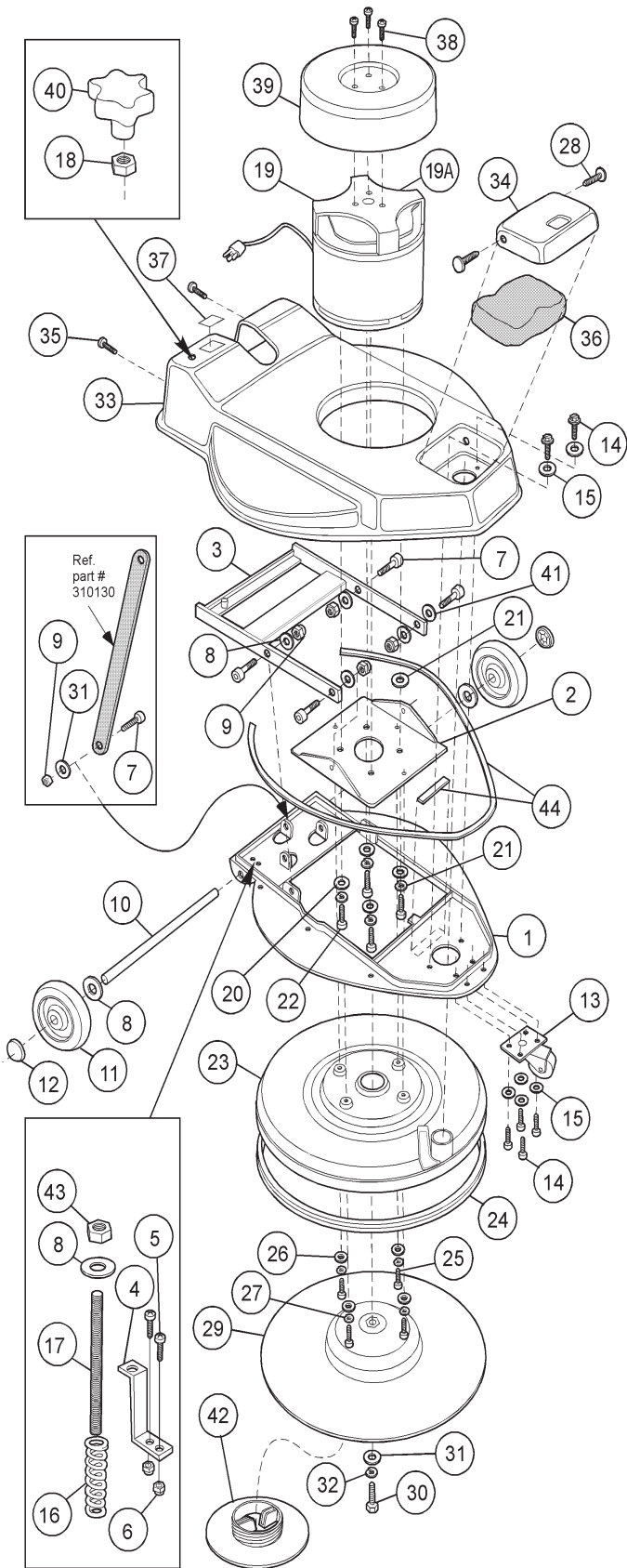

Item#	Part #	Description
1	E81117	Base, Steel
2	E81174	Plate, Motor Mount
3	E81173	Bracket, Dust Control Burnisher
4	E81172	Bracket, Spring Adjustment
5	E81089	Bolt, 5/16 - 18 X 3/4"
6	E81063	Nut, 5/16" Nylok
7	E81085	Bolt, Shoulder 1/2 x 3/8"
8	E83145	Washer, 1/2" Nylon
9	E81076	Nut, 3/8 Nylok Thin
10	E83651	Axle, 1/2 x 17.25"
11	E81124	Wheel, 5"
12	E83143	Cap, Axle 1/2"
13	E81126	Wheel, Caster 2.5"
14	E81082	Bolt, 1/4 - 20 X 3/8 with patch
15	E81713	Washer, Flat 1/4"
16	E81132	Spring, 4"
17	E81393	Rod, Threaded, spring adjustment 5"
18	E81079	Nut, 1/2"-13 Jam
19	E81109	Motor, 1.5 HP 115v 2000 RPM
19A	Internal Motor Parts	E85053 Carbon Brush, E85042 Rectifier
20	E81062	Washer, Flat 5/16" USS
21	E81066	Washer, Lock 3/8" Split
22	E81080	Bolt 3/8 - 16 x 3/4" Gr 5
23	E81144	Shroud, Dust
24	E83657	Brush, Extrusion, Skirt DC Burnisher
25	E83425	Screw, 1/4 - 20 X 1" Ph Tr Hd
26	E81173	Washer, Flat 1/4"
27	E81078	Washer, Lock 1/4" Split
28	E81071	Plug, Plastic ratchet 5/16"
29	E81149	Pad Driver, DC Burnisher
30	E81072	Bolt, 5/16 X 1"
31	E81062	Washer, Flat USS 5/16"
32	E81067	Washer, Lock 5/16" Split
33	E81142	Cover, DC Burnisher
34	E81143	Cover, Dust Bag DC Burnisher
35	E81074	Screw, 10-24 X 1/2 Truss Head Zn
36	E83788	Bag, Dust, Cloth
37	E83720	Decal, Brush Pressure DC Burnisher
38	E81523	Screw, 8-32 x 3/8 Ph Tr Hd
39	E81141	Cover, Motor
40	E81229	Knob, black, DC Burnisher
41	E83269	Washer, Spring 1/2 in.
42	E81150	Pad Holder, for replacement only
43	E81088	Nut, 1/2 x 13 thin nylok

# BURNISHER MODEL CREWMAN™ DC2000 PARTS

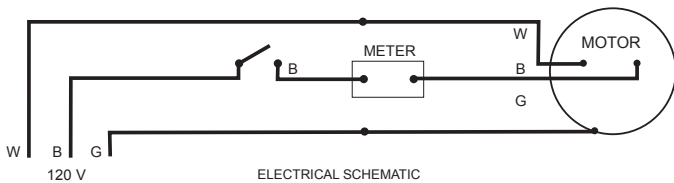
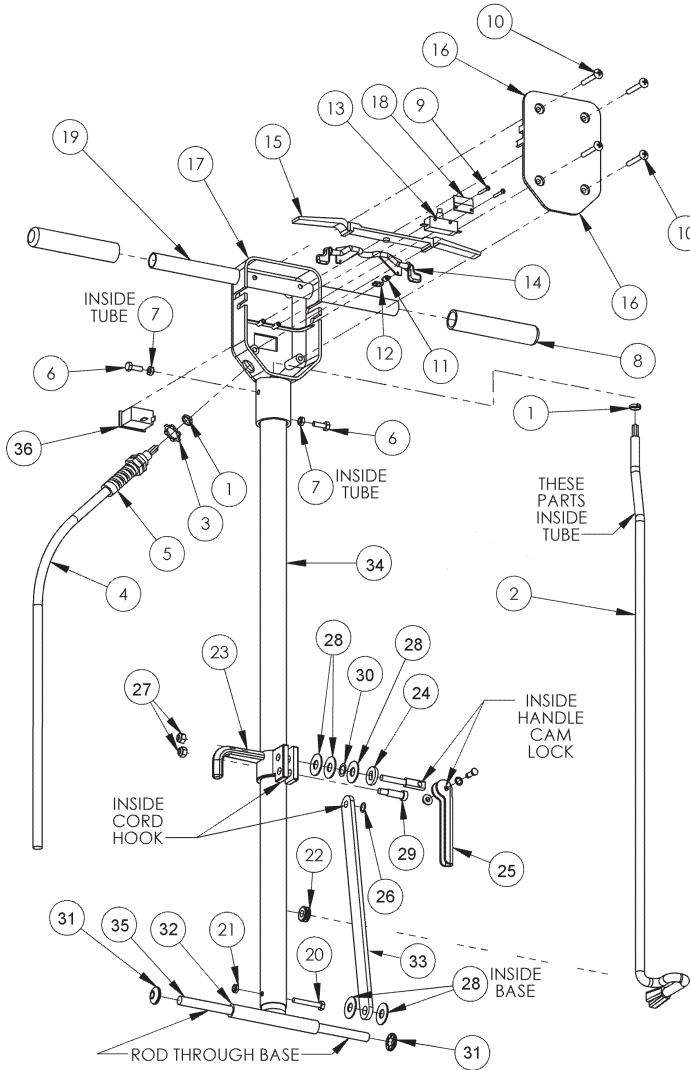

Not Shown EP50065 Cam Lock Handle Asm  
 Not Shown E85042 Rectifier  
 Not Shown E85053 Carbon Brush Set of 4

Item#	Part #	Description
1	E83523	Nylon Cable Tie
2	E83132	Cord, Handle, 14-3
3	E83789	Nut, Electrical Conduit, 1/2"
4	E83790	Cord, 50 Feet, 14-3ST
5	E83496	Strain Relief for Replacement
6	E81064	Bolt, Hex. 1/4-20 x 3/4
7	E83520	Nut, Nylock, 1/4-20
8	E83127	Grip
9	E83651	Screw, Phillips, No. 6x1
10	E83426	Screw, Phillips, 1/4-20 x 1.75"
11	E83130	Spring
12	E83270	Clip, Spring
13	E85032	Switch
14	E83129	Safety Lock
15	E82752	Trigger, Switch
16	E83325	Cover, Switch Box
17	EP50300	Switch Box Cover, Handle, Dual Speed
18	E81105	Plate, Switch
19	E83451	Handle Tube, 7/8 x 16
20	E81065	Bolt, Hex. 1/4-20 x 1.75" Grade 5
21	E81070	Nut, Nylock, 1/4-20
22	E83519	Grommet, .375" ID
23	E83137	Cord Hook
24	E83135	Oval Washer
25	E83133	Cam Lock Lever W/Pin & Bolt
	PE50064	Cam Lock Assembly Includes items 24, 25, 27, 28, 30
26	E81379	Washer, Spring, 3/8
27	E81063	Nut, Nylock, 5/16-18
28	E83145	Washer, Nylon
29	E81077	Bolt, Shoulder, 3/8 x 1
30	E83269	Washer, Spring, 1/2
31	E83143	Caps, Axle, 0.5
32	E82717	Handle Socket
33	E83136	Bracket, Flat Handle
34	E83711	Handle Tube
35	E81394	Axle, 1/2 x 6.625"
36	E81216	Meter, 15 Amp.



1001 Brown Avenue • Toledo, Ohio 43607-0127

Customer Service: 888-GO-BETCO • Fax: 800-445-5056 • Technical Service: 877-856-5954 • www.betco.com